



MOTORES ASÍNCRONOS TRIFÁSICOS CLASE DE EFICIENCIA SEGÚN IEC 600343-30

THREE-PHASE ASYNCHRONOUS MOTOR EFFICIENCY CLASS ACCORDING IEC 60034-30

1ª edición
1st edition



Series IE3-MS - IE3-EG 'Eficiencia premium'

Anexo al catálogo general CEMER correspondiente a medidas generales y datos eléctricos de los motores IE3.
Otros datos y condiciones, ver el citado catálogo.

IE3-MS - IE3-EG series 'Premium efficiency'

*Attachment to the CEMER main catalogue corresponding to the main dimensions and electrical data of IE3 motors.
Other data and conditions, please check the mentioned catalogue.*

COMPARATIVA COMPARATIVE



Curva de eficiencia en motores de 4 polos eficiencias IE1 IE2 e IE3.

Efficiency curve, 4 poles motor, IE1 IE2 IE3 efficiency.

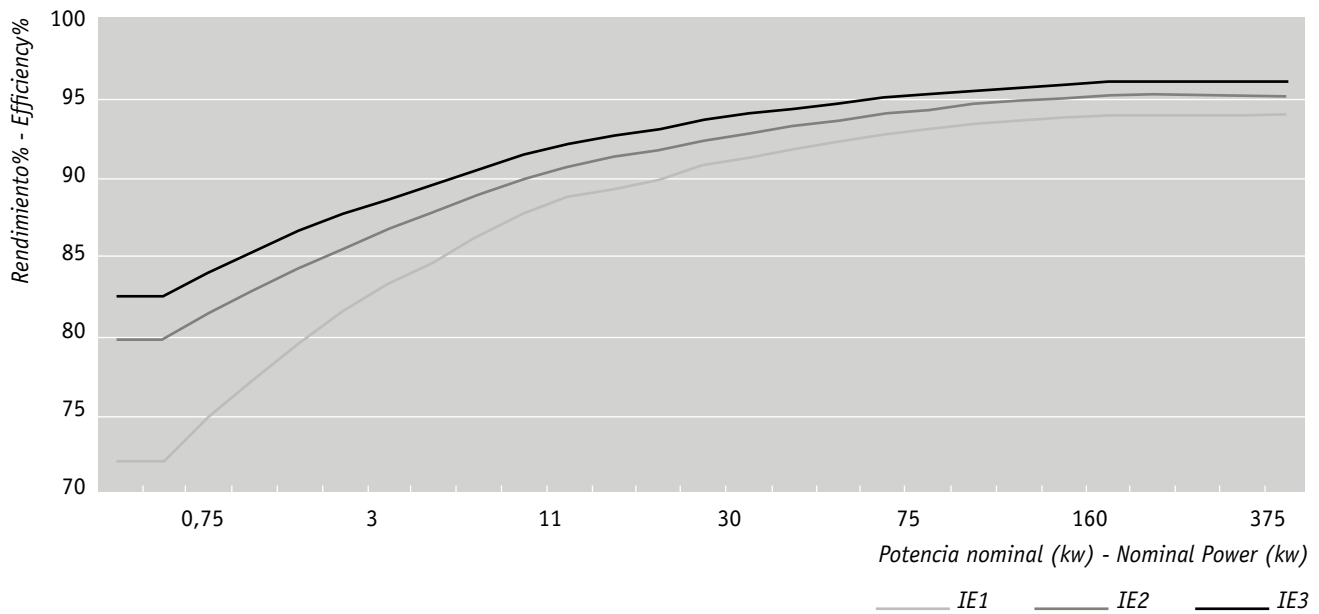

RODAMIENTOS / BEARINGS

Serie MS:

Rodamientos rígidos de una hilera de bolas, cerrados y lubricados de por vida (sellado de goma en ambas caras), y libres de mantenimiento.

Serie EG:

Rodamientos rígidos de una hilera de bolas, abiertos, y con dispositivo de re-engrase incorporado. Se deben engrasar con grasa de base lítica adecuada para rodamientos.

MS Series

Deep groove ball bearings, with double rubber sealing on each side, life lubricated and free of maintenance.

EG Series.

Deep groove ball bearings, fully open, with re-greasing Device. Lithium bearing grade of grease must be used.

Tamaño Frame	DE		NDE	
	2 poles	4-6 poles	2 poles	4-6 poles
IE3 MS 71	6202 2RS C3		6202 2RS C3	
IE3 MS 80	6204 2RS C3		6204 2RS C3	
IE3 MS 90	6205 2RS C3		6205 2RS C3	
IE3 MS 100	6206 2RS C3		6206 2RS C3	
IE3 MS 112	6306 2RS C3		6306 2RS C3	
IE3 MS 132	6308 2RS C3		6308 2RS C3	
IE3 MS 160	6309 2RS C3		6309 2RS C3	
IE3 EG 160	6309 C3		6309 C3	
IE3 EG 180	6311 C3		6311 C3	
IE3 EG 200	6312 C3		6312 C3	
IE3 EG 225	6312 C3	6313 C3	6312 C3	
IE3 EG 250	6313 C3	6314 C3	6313 C3	
IE3 EG 280	6314 C3	6317 C3	6314 C3	
IE3 EG 315	6317 C3	NU 319	6317 C3	6319 C3
IE3 EG 355	6319 C3	NU 322	6319 C3	6322 C3

PINTURA / PAINTING

Pintura Epoxi - Color RAL 7022 - "Gris de umbría".

Epoxi paint - RAL 7022 Colour - "Umbrá grey".

DATOS ELÉCTRICOS

Motores asincronos trifásicos con jaula de ardilla.
Ventilación exterior IC 4II, servicio continuo S1.
Clase de aislamiento 155(F), grado de protección IP55

Motores en aluminio serie IE3-MS
Motores en fundición serie IE3-EG

ELECTRICAL DATA

*Asynchronous three-phase motors, squirrel-case motor.
External cooling IC 4II, continuous service S1.
Isolating class 155(F), protection grade IP55.*

*Aluminum motors IE3-MS series.
Cast Iron motors IE3-EG series.*

Velocidad de sincronismo 3000 rpm - 2 polos / Synchronous speed 3000 rpm - 2 poles.

400V, 50Hz

TIPO TYPE	Potencia Power		I (A)			Eff			cosφ	Velocidad Speed rpm	kg
	kW	Cv	230V	400V	690V	100%	75%	50%			
IE3 MS 71 3-2	0,75	1	2,87	1,66	0,96	80,7%	81,0		0,82	2850	8,3
IE3 MS 80 1-2	0,75	1	2,81	1,62	0,94	80,7%	81,0		0,83	2850	10,4
IE3 MS 80 2-2	1,1	1,5	4,07	2,35	1,36	82,7%	83,0		0,83	2860	13,3
IE3 MS 90 S-2	1,5	2	5,38	3,11	1,80	84,2%	84,4		0,83	2860	15,4
IE3 MS 90 L1-2	2,2	3	7,56	4,38	2,53	85,9%	86,1		0,85	2860	19
IE3 MS 90 L2-2	3	4	10,5	5,8	3,35	83,0%	83,6		0,86	2830	22
IE3 MS 100 L1-2	3	4	10,0	5,8	3,35	87,1%	87,3		0,86	2880	25,9
IE3 MS 112 M-2	4	5,5	13,2	7,65	4,42	88,1%	88,3		0,86	2880	34
IE3 MS 132 S1-2	5,5	7,5	17,6	10,1	5,86	89,2%	89,4		0,88	2890	44,9
IE3 MS 132 S2-2	7,5	10	23,8	13,7	7,91	90,1%	90,3		0,88	2910	61,3
IE3 MS 160 M1-2	11	15	33,7	19,4	11,2	91,2%	91,4		0,90	2930	86,3
IE3 MS 160 M2-2	15	20	45,5	26,3	15,2	91,9%	92,2		0,90	2940	101,4
IE3 MS 160 L-2	18,5	25	55,2	31,9	18,4	92,4%	92,6		0,91	2940	119,7
IE3 EG 160 M1-2	11	15		19,6	11,3	91,2%	91,1%	89,6%	0,89	2940	145
IE3 EG 160 M2-2	15	20		26,5	15,3	91,9%	91,8%	90,4%	0,89	2940	160
IE3 EG 160 L-2	18,5	25		32,5	18,8	92,4%	92,3%	91,0%	0,89	2940	175
IE3 EG 180 M-2	22	30		38,5	22,3	92,7%	92,6%	91,3%	0,89	2950	215
IE3 EG 200 L1-2	30	40		52,1	30,2	93,3%	93,2%	92,0%	0,89	2960	290
IE3 EG 200 L2-2	37	50		64	37,1	93,7%	93,6%	92,5%	0,89	2960	310
IE3 EG 225 M-2	45	60		77,6	45	94,0%	93,9%	92,9%	0,89	2970	390
IE3 EG 250 M-2	55	75		94,6	54,8	94,3%	94,2%	93,3%	0,89	2970	520
IE3 EG 280 S-2	75	100		128	74	94,7%	94,6%	93,7%	0,89	2980	680
IE3 EG 280 M-2	90	125		154	89	95,0%	94,9%	94,0%	0,89	2980	725
IE3 EG 315 S-2	110	150		185	107	95,2%	95,1%	94,2%	0,9	2980	940
IE3 EG 315 M-2	132	180		222	129	95,4%	95,3%	94,4%	0,9	2980	1050
IE3 EG 315 L1-2	160	220		265	154	95,6%	95,5%	95,0%	0,91	2980	1130
IE3 EG 315 L2-2	200	270		331	192	95,8%	95,7%	95,0%	0,91	2980	1195
IE3 EG 355 M-2	250	340		414	240	95,8%	95,7%	95,0%	0,91	2980	consult
IE3 EG 355 L1-2	315	430		522	302	95,8%	95,7%	95,0%	0,91	2980	consult
IE3 EG 355 L2-2	355	470		588	341	95,8%	95,7%	95,0%	0,91	2980	consult

* Los datos eléctricos no son vinculantes a las series, para mas exactitud consultar. Datos correspondientes a las series MSE y EGQ.

* The electrical data are not restricted to the series, for more detailed information please ask. Corresponding data to EGQ and MSE series.

DATOS ELÉCTRICOS

Motores asincronos trifásicos con jaula de ardilla.
Ventilación exterior IC 4II, servicio continuo S1.
Clase de aislamiento 155(F), grado de protección IP55

Motores en aluminio serie IE3-MS
Motores en fundición serie IE3-EG

ELECTRICAL DATA

*Asynchronous three-phase motors, squirrel-case motor.
External cooling IC 4II, continuous service S1.
Isolating class 155(F), protection grade IP55.*

*Aluminum motors IE3-MS series.
Cast Iron motors IE3-EG series.*

Velocidad de sincronismo 1500 rpm - 4 polos / Synchronous speed 1500 rpm - 4 poles.

400V, 50Hz

TIPO TYPE	Potencia Power		I (A)			Eff			cosφ	Velocidad Speed rpm	kg
	kW	Cv	230V	400V	690V	100%	75%	50%			
IE3 MS 80 2-4	0,75	1	2.93	1.69	0.98	82.5	82.7		0,78	1390	12,45
IE3 MS 90 S-4	1,1	1,5	4.15	2.4	1.39	84.1	84.4		0,79	1390	15,95
IE3 MS 90 L-4	1,5	2	5.52	3.19	1.84	85.3	85.5		0,8	1400	19
IE3 MS 100 L1-4	2.2	3	7.96	4.6	2.65	86.7	86.9		0,8	1410	24,9
IE3 MS 100 L2-4	3	4	10.6	6.12	3.53	87.7	87.8		0,81	1420	29,2
IE3 MS 112 M-4	4	5,5	13.9	8.02	4.64	88.1	88.3		0,82	1430	37,6
IE3 MS 132 S-4	5.5	7,5	18.6	10.8	6.2	89.6	89.7		0,83	1440	50
IE3 MS 132 M-4	7.5	10	24.8	14.3	8.3	90.4	90.6		0,84	1450	58
IE3 MS 160 M-4	11	15	35.2	20.3	11.7	91.4	91.6		0,86	1460	96,8
IE3 MS 160 L-4	15	20	47	27.2	15.7	92.1	92.5		0,87	1460	111,4
IE3 EG 160 M-4	11	15		20,4	11,8	91.4%	91.3%	90.3%	0,85	1470	150
IE3 EG 160 L-4	15	20		27,3	15,8	92.1%	92.0%	90.6%	0,86	1470	180
IE3 EG 180 M-4	18,5	25		33,5	19,4	92.6%	92.5%	91.2%	0,86	1475	225
IE3 EG 180 L-4	22	30		39,7	23	93.0%	92.9%	91.7%	0,86	1475	240
IE3 EG 200 L-4	30	40		53,8	31,2	93.6%	93.5%	92.4%	0,86	1475	320
IE3 EG 225 S-4	37	50		66,1	38,3	93.9%	93.8%	92.7%	0,86	1480	390
IE3 EG 225 M-4	45	60		80,2	46,5	94.2%	94.1%	93.1%	0,86	1480	410
IE3 EG 250 M-4	55	75		97,6	56,6	94.6%	94.5%	94.0%	0,86	1480	575
IE3 EG 280 S-4	75	100		129	75	95.0%	94.9%	94.0%	0,88	1485	725
IE3 EG 280 M-4	90	125		155	90	95.2%	95.1%	94.5%	0,88	1485	765
IE3 EG 315 S-4	110	150		189	110	95.4%	95.3%	94.4%	0,88	1480	1060
IE3 EG 315 M-4	132	180		226	131	95.6%	95.5%	94.5%	0,88	1480	1185
IE3 EG 315 L1-4	160	220		271	157	95.8%	95.7%	95.0%	0,89	1480	1270
IE3 EG 315 L2-4	200	270		338	196	96.0%	95.9%	95.0%	0,89	1480	1400
IE3 EG 355 M-4	250	340		418	242	96.0%	95.9%	95.1%	0,9	1490	consult
IE3 EG 355 L1-4	315	430		526	305	96.0%	95.9%	95.1%	0,9	1490	consult
IE3 EG 355 L2-4	355	470		607	352	96.0%	95.9%	95.1%	0,88	1490	consult

* Los datos eléctricos no son vinculantes a las series, para mas exactitud consultar. Datos correspondientes a las series MSE y EGQ.

* The electrical data are not restricted to the series, for more detailed information please ask. Corresponding data to EGQ and MSE series.

DATOS ELÉCTRICOS

Motores asincronos trifásicos con jaula de ardilla.
Ventilación exterior IC 4II, servicio continuo S1.
Clase de aislamiento 155(F), grado de protección IP55

Motores en aluminio serie IE3-MS
Motores en fundición serie IE3-EG

ELECTRICAL DATA

*Asynchronous three-phase motors, squirrel-case motor.
External cooling IC 4II, continuous service S1.
Isolating class 155(F), protection grade IP55.*

*Aluminum motors IE3-MS series.
Cast Iron motors IE3-EG series.*

Velocidad de sincronismo 1000 rpm - 6 polos / Synchronous speed 1000 rpm - 6 poles.

400V, 50Hz

TIPO TYPE	Potencia Power		I (A)			Eff			cosφ	Velocidad Speed rpm	kg
	kW	Cv	230V	400V	690V	100%	75%	50%			
IE3 MS 90 S-6	0.75	1	3.3	1.9	1.1	78.9	79.1		0,72	910	15
IE3 MS 90 L-6	1.1	1,5	4.67	2.7	1.6	81	81.3		0,73	920	20
IE3 MS 100 L-6	1.5	2	6	3.47	2	82.5	82.7		0,76	935	27
IE3 MS 112 M-6	2.2	3	8.63	5	2.88	84.3	84.6		0,76	940	35,5
IE3 MS 132 S-6	3	4	11.6	6.7	3.86	85.6	85.8		0,76	940	46
IE3 MS 132 M1-6	4	5,5	14.82	8.56	5	86.8	86.9		0,76	950	55
IE3 MS 132 M2-6	5.5	7,5	20.4	11.8	6.8	88	88.2		0,77	950	65,5
IE3 MS 160 M-6	7.5	10	27.5	15.85	9.15	89.1	89.4		0,77	950	123
IE3 MS 160 L-6	11	15	38.7	22.4	12.9	90.3	90.5		0,79	950	138
IE3 EG 160 M-6	7,5	10		15,6	9	89.1%	89.0%	87.2%	0,78	975	140
IE3 EG 160 L-6	11	15		22,3	12,9	90.3%	90.2%	88.6%	0,79	975	160
IE3 EG 180 L-6	15	20		29,3	17	91.2%	91.1%	89.6%	0,81	975	220
IE3 EG 200 L1-6	18,5	25		36	20,8	91.7%	91.6%	90.2%	0,81	975	260
IE3 EG 200 L2-6	22	30		42	24,3	92.2%	92.1%	90.8%	0,82	975	290
IE3 EG 225 M-6	30	40		57,5	33,4	92.9%	92.8%	91.6%	0,81	980	360
IE3 EG 250 M-6	37	50		68,1	39,5	93.3%	93.2%	92.3%	0,84	980	470
IE3 EG 280 S-6	45	60		80,6	46,7	93.7%	93.6%	92.5%	0,86	980	600
IE3 EG 280 M-6	55	75		98,1	56,9	94.1%	94.0%	93.3%	0,86	980	645
IE3 EG 315 S-6	75	100		135	78	94.6%	94.5%	93.6%	0,85	990	940
IE3 EG 315 M-6	90	125		163	94,5	94.9%	94.8%	93.7%	0,84	990	1040
IE3 EG 315 L1-6	110	150		196	114	95.1%	95.0%	94.1%	0,85	990	1110
IE3 EG 315 L2-6	132	180		232	135	95.4%	95.3%	94.5%	0,86	990	1115
IE3 EG 355 M1-6	160	220		281	163	95.6%	95.5%	95.0%	0,86	990	
IE3 EG 355 M2-6	200	270		346	201	95.8%	95.7%	95.0%	0,87	990	
IE3 EG 355 L-6	250	340		433	251	95.8%	95.7%	95.0%	0,87	990	

* Los datos eléctricos no son vinculantes a las series, para mas exactitud consultar. Datos correspondientes a las series MSE y EGQ.

* The electrical data are not restricted to the series, for more detailed information please ask. Corresponding data to EGQ and MSE series.

DIMENSIONES

Motores de aluminio serie IE3 MS

Formas constructivas B3 - B5 - B5R - B14 - B14G

DIMENSIONS

Aluminum motors IE3 MS series

Construction types B3 - B5 - B5R - B14 - B14G

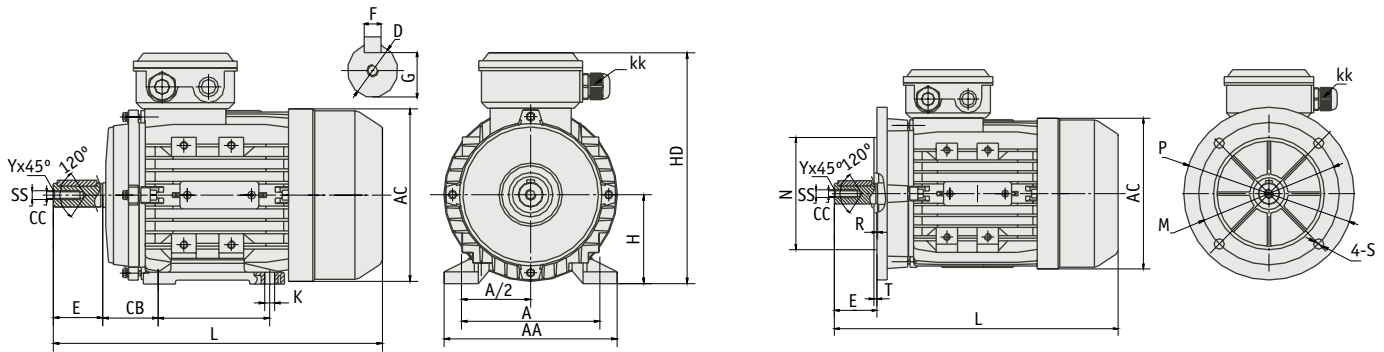

IM B3 / IM 1001											Tolerancias Eje J6 Shaft Tolerances J6					IM B5 / IM 3001 Taladros a 45° / Holes at 45°				
Frame	A	AA	AC	B	C	H	HD	K	KK	L	D	SS	E	F	G	M	N	P	S	T
80	125	160	158	100	50	80	212	10	1 - M20x1.5	295	19	M6	40	6	15,5	165	130	200	12	3,5
90 S	140	180	179	100	56	90	228	10	1 - M20x1.5	335	24	M8	50	8	20	165	130	200	12	3,5
90 L	140	180	179	125	56	90	228	10	1 - M20x1.5	365	24	M8	50	8	20	165	130	200	12	3,5
100	160	200	203	140	63	100	260	12	1 - M20x1.5	400	28	M10	60	8	24	215	180	250	15	4.0
112 M	190	233	225	140	70	112	285	12	2 - M25x1.5	410	28	M10	60	8	24	215	180	250	15	4.0
112 L	190	233	225	140	70	112	285	12	2 - M25x1.5	440	28	M10	60	8	24	215	180	250	15	4.0
132 S	216	255	265	140	89	132	325	12	2 - M25x1.5	430	38	M12	80	10	33	265	230	300	15	4.0
132 M	216	255	265	178	89	132	325	12	2 - M25x1.5	470	38	M12	80	10	33	265	230	300	15	4.0
160	254	290	315	254	108	160	390	15	2 - M40x1,5	633	42	M16	110	12	37	300	250	350	19	5.0

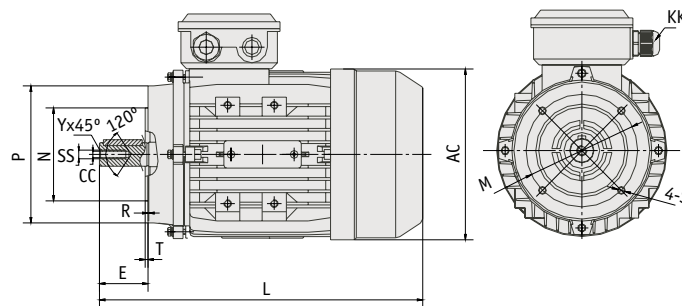

IM B5R Taladros a 45° / Holes at 45°					
Frame	M	N	P	S	T
80	130	110	160	12	3.5
90	130	110	160	12	3.5
100	165	130	200	15	3.5
112	165	130	200	15	3.5
132	215	180	250	15	4.0

IM B14 / IM 3601 Taladros a 45° / Holes at 45°					
Frame	M	N	P	S	T
80	100	80	120	M6	3.0
90	115	95	140	M8	3.0
100	130	110	160	M8	3.5
112	130	110	160	M8	3.5
132	165	130	200	M10	4.0

IM B14G / IM 3601 G Taladros a 45° / Holes at 45°					
Frame	M	N	P	S	T
80	130	110	160	M8	3.5
90	130	110	160	M8	3.5
100	165	130	200	M10	3.5
112	165	130	200	M10	3.5
132	215	180	250	M12	4

DIMENSIONES

Motores de fundición serie IE3 EG
Formas constructivas B3 - B5

DIMENSIONS

Cast Iron motors IE3 EG series
Construction types B3 - B5

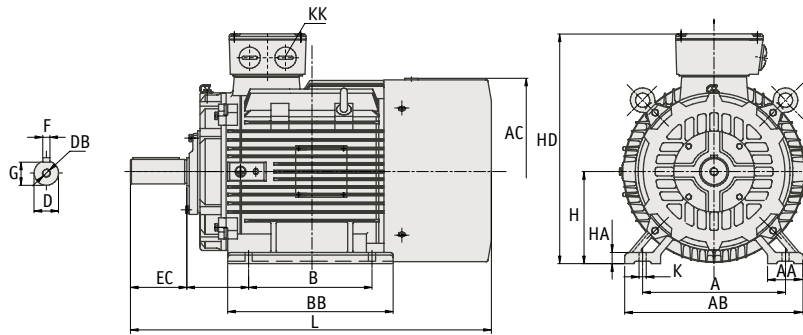

IM B3 / IM 1001															
Frame	Poles	A	AB	AC	B	C	H	HD	K	KK	L	D	E	F	G
160 M	2-4-6	254	320	330	214	108	160	420	15	2 x M40x1,5	700	42	110	12	37
160 L	2-4-6	254	320	330	254	108	160	420	15	2 x M40x1,5	740	42	110	12	37
180 M	2-4-6	279	355	380	241	121	180	455	15	2 x M40x1,5	790	48	110	14	42,5
180 L	2-4-6	279	355	380	279	121	180	455	15	2 x M40x1,5	790	48	110	14	42,5
200 L	2-4-6	318	395	420	305	133	200	505	19	2 x M50x1,5	830	55	110	16	49
225 S	4	356	435	470	286	149	225	560	19	2 x M50x1,5	830	60	140	18	53
225 M	2	356	435	470	311	149	225	560	19	2 x M50x1,5	825	55	110	16	49
225 M	4-6	356	435	470	311	149	225	560	19	2 x M50x1,5	855	60	140	18	53
250 M	2	406	490	510	349	168	250	615	24	2 x M63x1,5	915	60	140	18	53
250 M	4-6	406	490	510	349	168	250	615	24	2 x M63x1,5	915	65	140	18	58
280 S	2	457	550	580	368	190	280	680	24	2 x M63x1,5	985	65	140	18	58
280 S	4-6	457	550	580	368	190	280	680	24	2 x M63x1,5	985	75	140	20	67,5
280 M	2	457	550	580	419	190	280	680	24	2 x M63x1,5	1035	65	140	18	58
280 M	4-6	457	550	580	419	190	280	680	24	2 x M63x1,5	1035	75	140	20	67,5
315 S	2	508	635	645	406	216	315	845	28	2 x M63x1,5	1180	65	140	18	58
315 S	4-6	508	635	645	406	216	315	845	28	2 x M63x1,5	1290	80	170	22	71
315 M	2	508	635	645	457	216	315	845	28	2 x M63x1,5	1210	65	140	18	58
315 M	4-6	508	635	645	457	216	315	845	28	2 x M63x1,5	1320	80	170	22	71
315 L	2	508	635	645	508	216	315	845	28	2 x M63x1,5	1210	65	140	18	58
315 L	4-6	508	635	645	508	216	315	845	28	2 x M63x1,5	1320	80	170	22	71
355 M	2	610	730	710	560	254	355	1010	28	2 x M72x2,0	1500	75	140	20	67,5
355 M	4-6	610	730	710	560	254	355	1010	28	2 x M72x2,0	1530	100	210	28	90
355 L	2	610	730	710	630	254	355	1010	28	2 x M72x2,0	1500	75	140	20	67,5
355 L	4-6	610	730	710	630	254	355	1010	28	2 x M72x2,0	1530	100	210	28	90

IM B5 / IM 3001						
Frame	P	N	M	S	T	LA
160	350	250	300	4 x d.18,5	5	15
180	350	250	300	4 x d.18,5	5	15
200	400	300	350	4 x d.18,5	5	17
225	450	350	400	8 x d.18,5	5	20
250	550	450	500	8 x d.18,5	5	22
280	550	450	500	8 x d.18,5	5	22
315	660	550	600	8 x d.24	6	22
355	800	680	740	8 x d.24	6	25

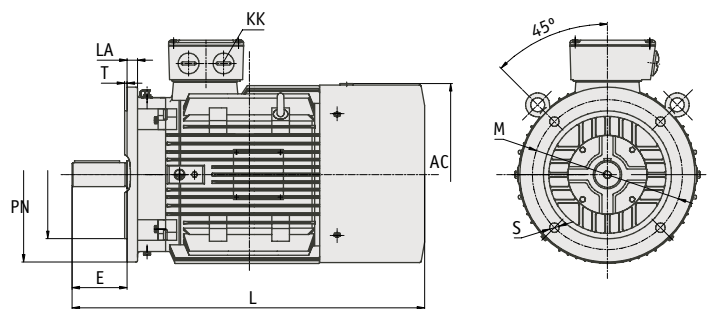

REPARK
WWW.REPARK.LV

 **cosgra**_{SA}



CIERRES MECÁNICOS PARA EJES ROTATIVOS

MOTORES ELÉCTRICOS, CA: Monofásicos / Trifásicos / Autofrenantes / Antiexplosivos / Antideflagrantes / Velocidad variable

MOTOTAMBORES Y RODILLOS MOTORIZADOS

REDUCTORES: Vis sin fin / Con prereducción / Doble vis sin fin / Variadores / Discos planetarios

ELECTRIC MOTORS, CA: Single Phase / Three Phase / Braking / Anti-explosion / Flameproof / Variable speed

GEARED MOTORS: Worm series / Pre-stage helical units / Combined worm / Variators / Series stepless speed

MECHANICAL SEALS FOR ROTARY SHAFTS

MOTORISED DRUMS AND MOTORISED PULLEYS

Ctra. de Banyoles a Figueres, Km 9 _ Telf. - +34 972 597 807 _ Skype: cosgra.sa _ Fax +34 972 597 233

www.cosgra.com _ comercial@cosgra.com _ 17832 **CRESPIÀ** (Girona) _ SPAIN

Apartado 100 _ 17820 **BANYOLES** (Girona)

(E) Esponellà Latitud: 42°10'42.6"N Longitud: 2°48'04.9"E Altitud: 120 m.

CIME GRUP

ROTEN



E.M.G.



RAEL UVEB

JAWAC

YILMAZ