

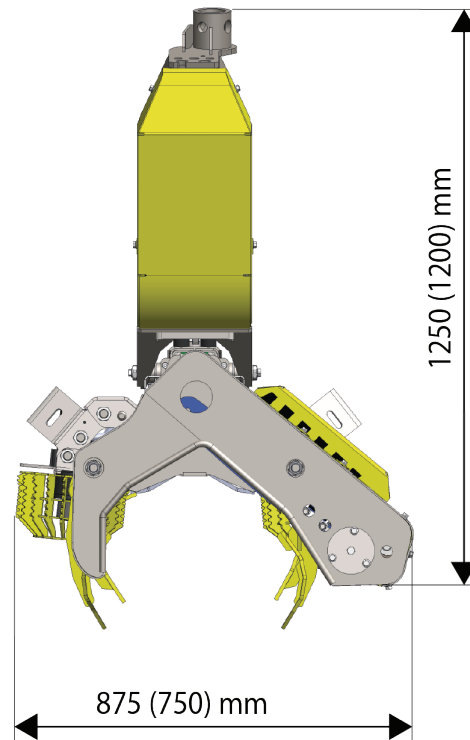

SYKETEC

JOB0 ST50
Product program

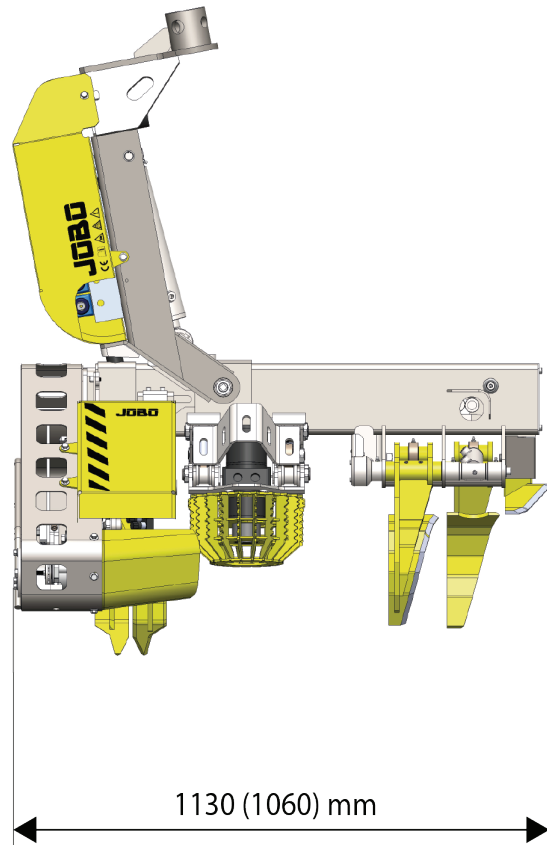



JOBO ST50 Combi / Bambi

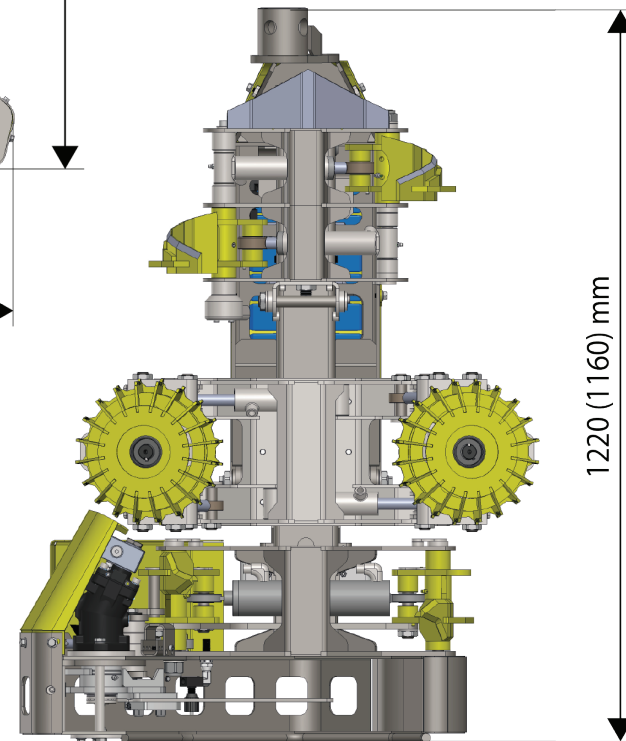

- Måtten inom parentes är för ST50 Bambi
- Sulussa olevat mitat ovat ST50 Bambin mitat
- Measures within parentesis are for ST50 Bambi

Specification

Specification	JOBO ST50 Bambi	JOBO ST50 Combi
Weight, base machine	205 kg	265 kg
Fell diameter	30 cm	30 cm
Delimiting diameter	25-3 cm	25-3 cm
Saw bar/chain	42/48cm, 2mm, .404	42/48cm, 2mm, .404
Oil requirement	40 - 60 l/min	50 - 80 l/min
Hydraulic pressure	190 bar	200 bar
Stroke length	50 cm	50 cm
Feed force, ø40/32 mm	23/15 kN	23/15 kN
Speed of stroke	0,75 m/sec	0,75 m/sec
Roll feed	-	2,1 m/sec

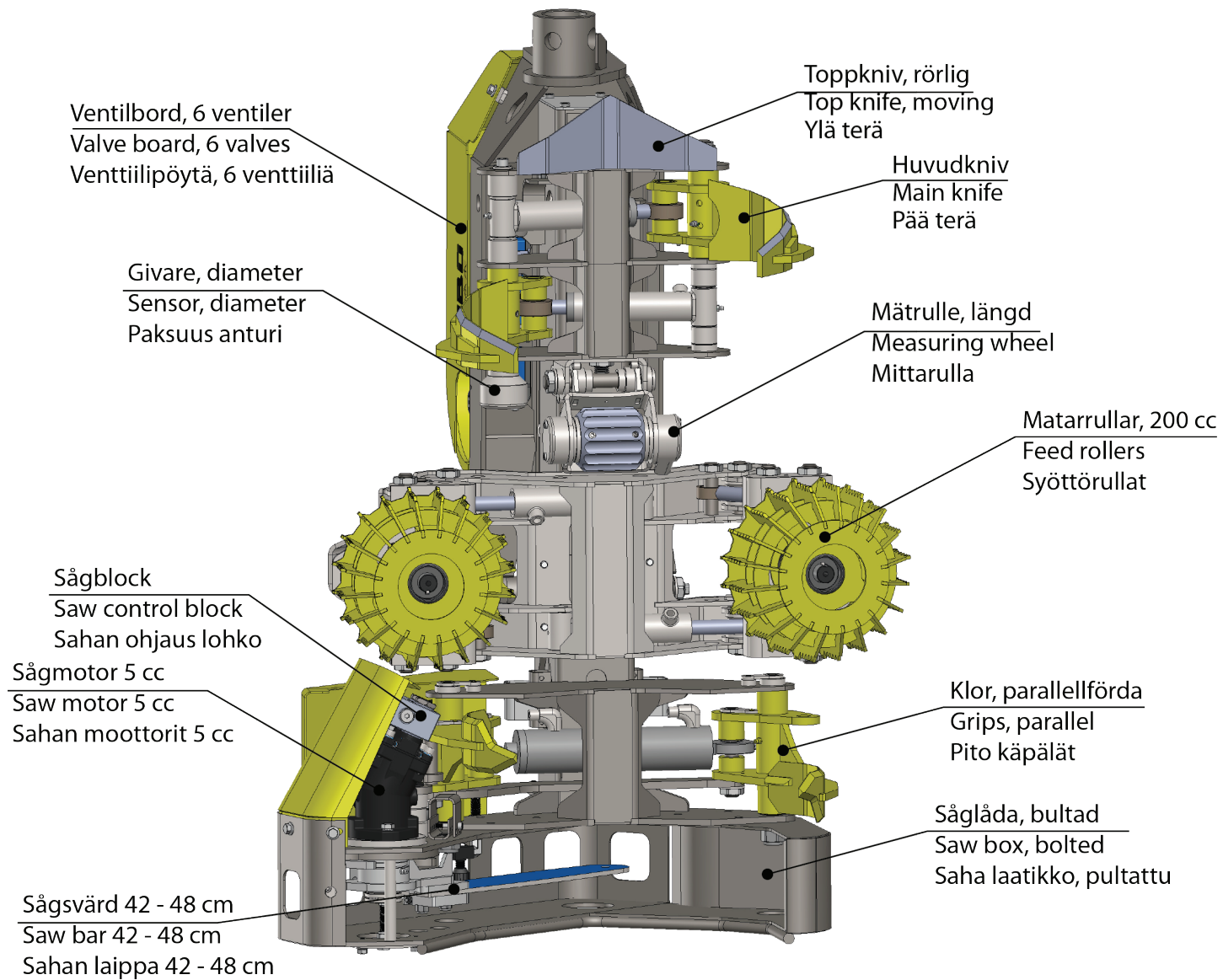

Harvester JOBO ST50-scope selection

Specification	JOBO ST50 Bambi	JOBO ST50 Combi
Saw limiter	Standard	Standard
Stump treatment	Option	Option
Moving knives	3 pcs	3 pcs
Feed rolls	-	Option
Length measure, stroke	Standard	Standard
Length measure by roller	Option	Option
Diameter measure	Option	Option
Volume calc. (top/middle)	CAN-MID	CAN-MID

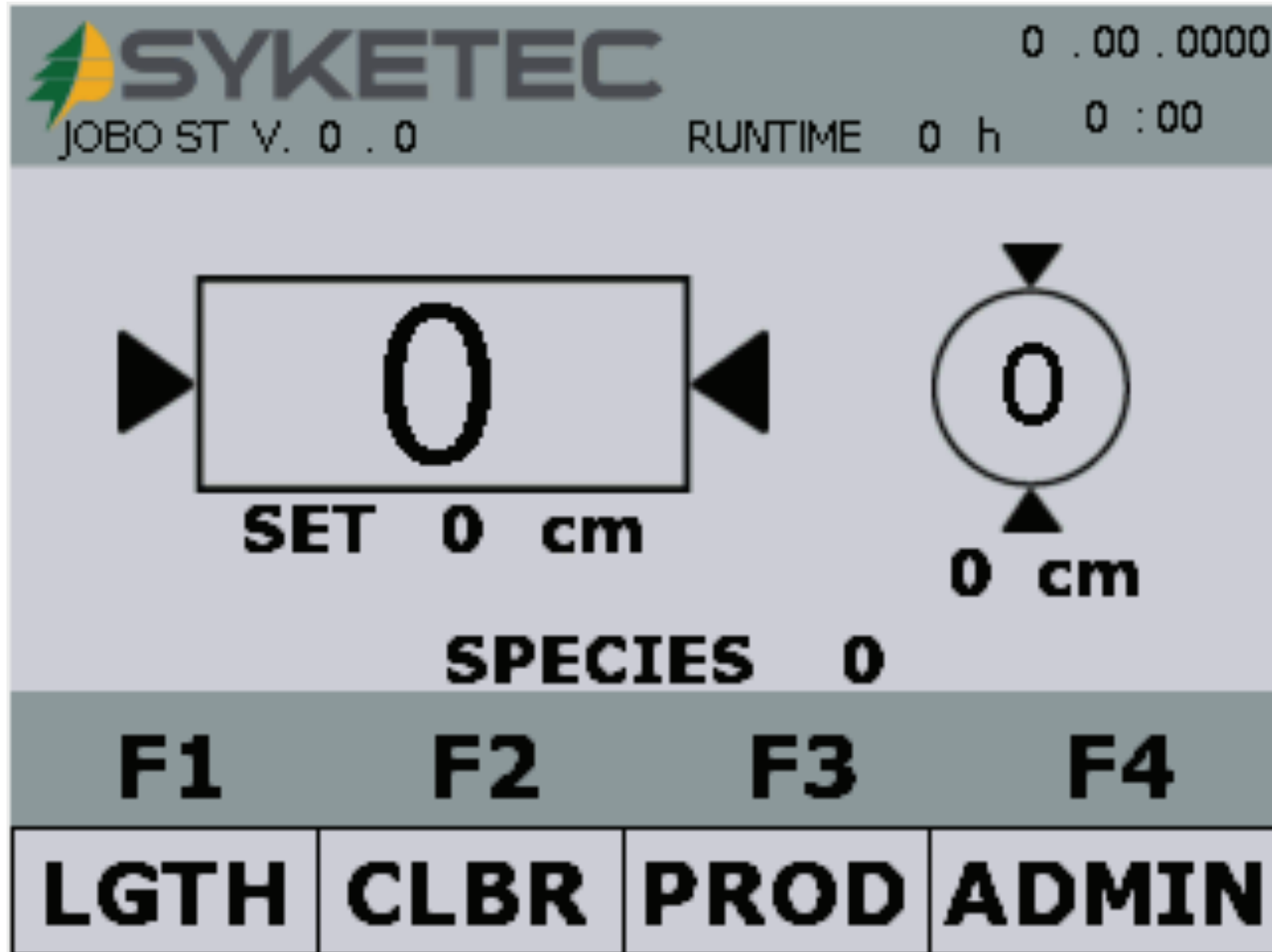



Measuring system CAN-CCD

JOBO CAN CCD is the controller for all functions of the harvester head. The operator can fine tune functions all depending on actual oil flow and temperature. The selection of species and length preselection are simple by means of menu's and buttons.

Technical features:

- Operating voltage 9 - 32 VDC
- Operating temperature -20 - +60°C
- LCD display 3,7in QVGA
- Frame, aluminium IP67
- Interface CAN 2.0B
- Real time clock

This system can be built in two separate units (as in picture) or in single unit panel. Installation space requirement is judging.

Control system features

Specification	JOBO ST50 Bambi	JOBO ST50 Combi
Select operation mode	F1 - stroke	F1 - F4, COMBI
Feed to preselection	Automatic	Automatic
Select species	Six (6) preselections	Six (6) preselections
Length selection	Six (6) lengths	Six (6) lengths
Multi stem/ Multi grip selection	-	With rolls
Volume calculation	CAN-MID	CAN-MID
Crane controls	CAN-CCD/MID	CAN-CCD/MID
Internal diagnostic	CAN-CCD/MID	CAN-CCD/MID
Production recording	CAN-CCD/MID	CAN-CCD/MID



Measuring system CAN-MID

JOBO CAN MID is the more advanced measuring and control system built on high quality hardware with sophisticated features. The operating system Linux provides calculation power and easy to use menus to adjust all functions and even follow-up of produced volumes.

Technical features:

- Operating voltage 9 - 32 VDC
- Operating temperature -20 - +60°C
- LCD display 7in QVGA
- Frame, aluminium IP67
- Interface CAN 2.0B
- Connector 44 pin AMP
- Real time clock, 4 - video inputs

This system can be built in two separate units or in single unit panel (as in picture) . Installation space requirement is judging.

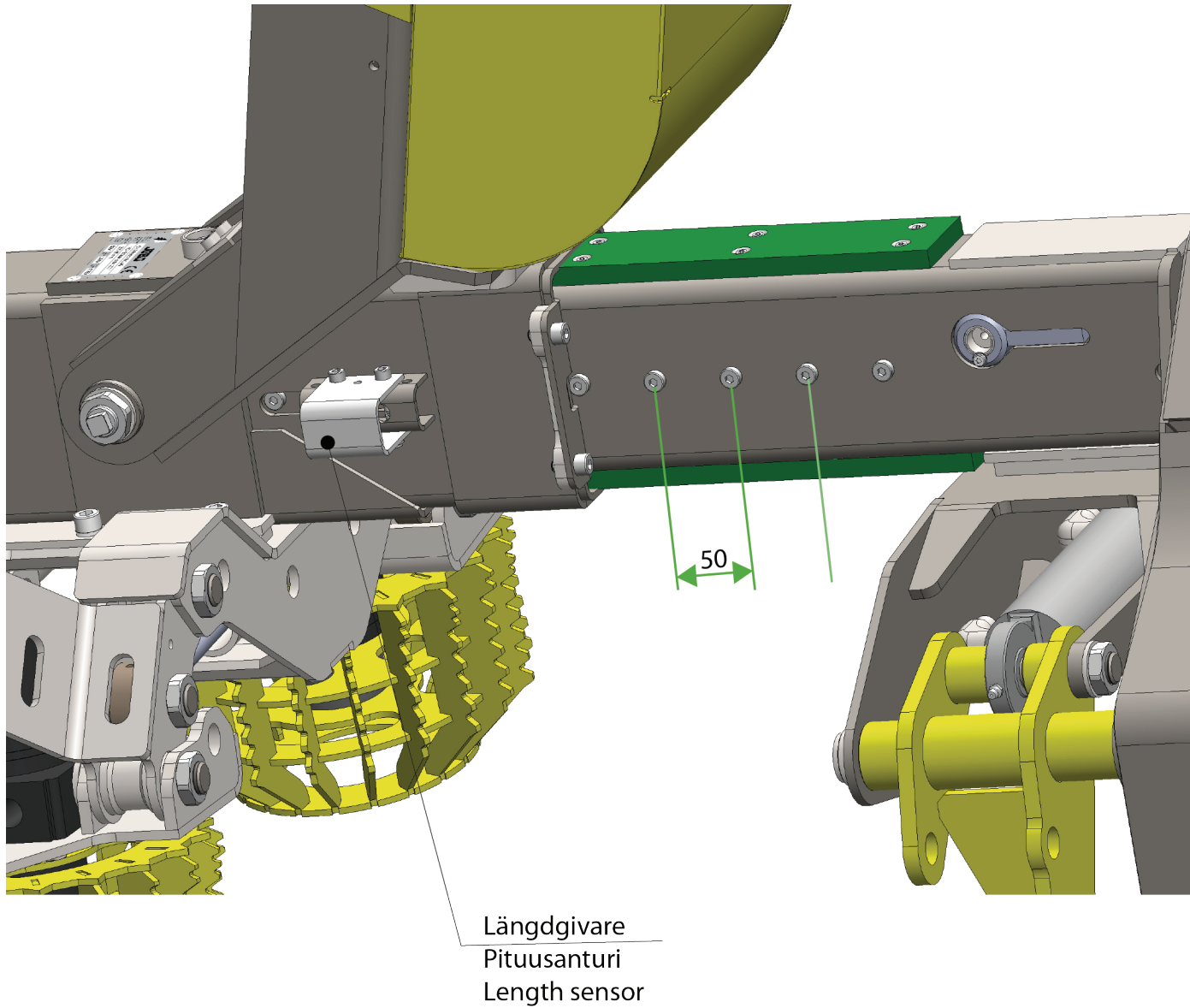

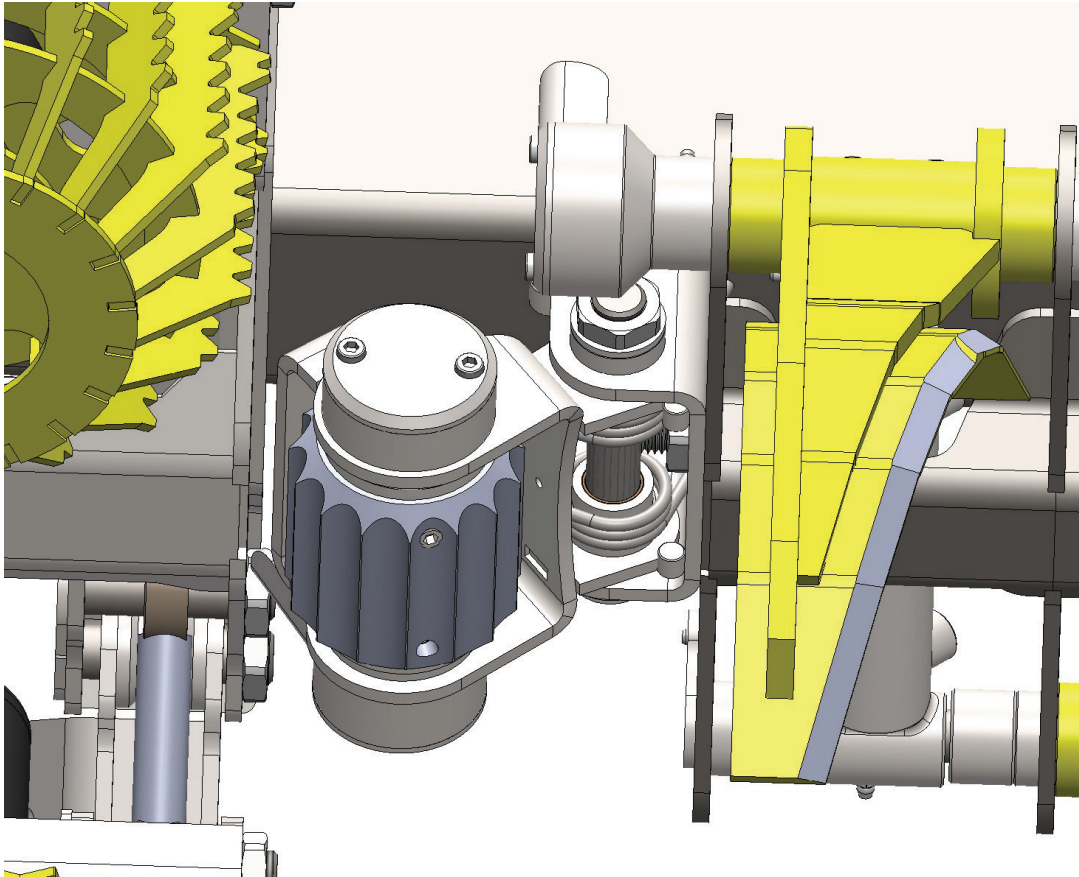

Length measuring methods

All JOBO harvester heads include length measure taken from the stroke. Length sensor is calculating length with 5 cm intervals. More accurate measurement can be achieved with the optional measuring wheel.

Technical features:

- Measuring wheel diam. 80mm (L=26cm)
- Spring loaded
- Magnetic (HALL) sensor, 32 pulses/turn
- Theoretical accuracy 0,7 cm

The measuring wheel is counting forward and backward as it follows the tree stem. Measuring wheel can be retrofitted.

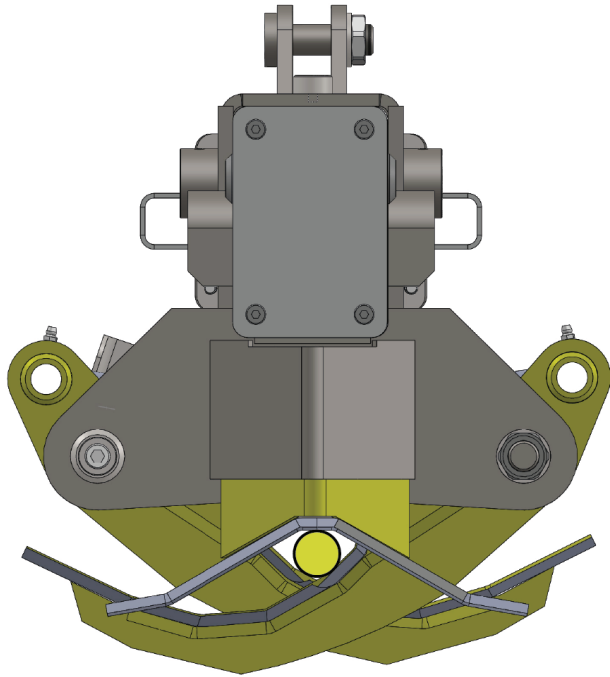

Min diam. 20 - 30 mm

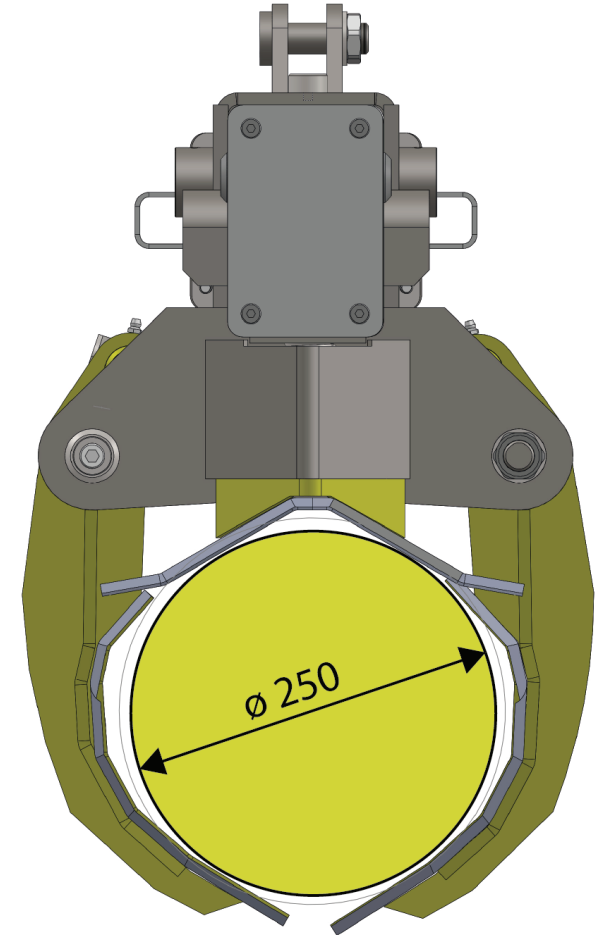
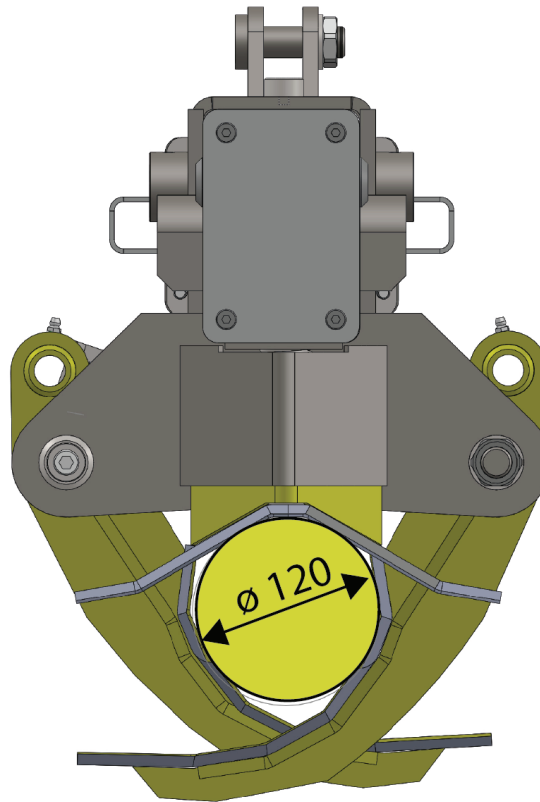

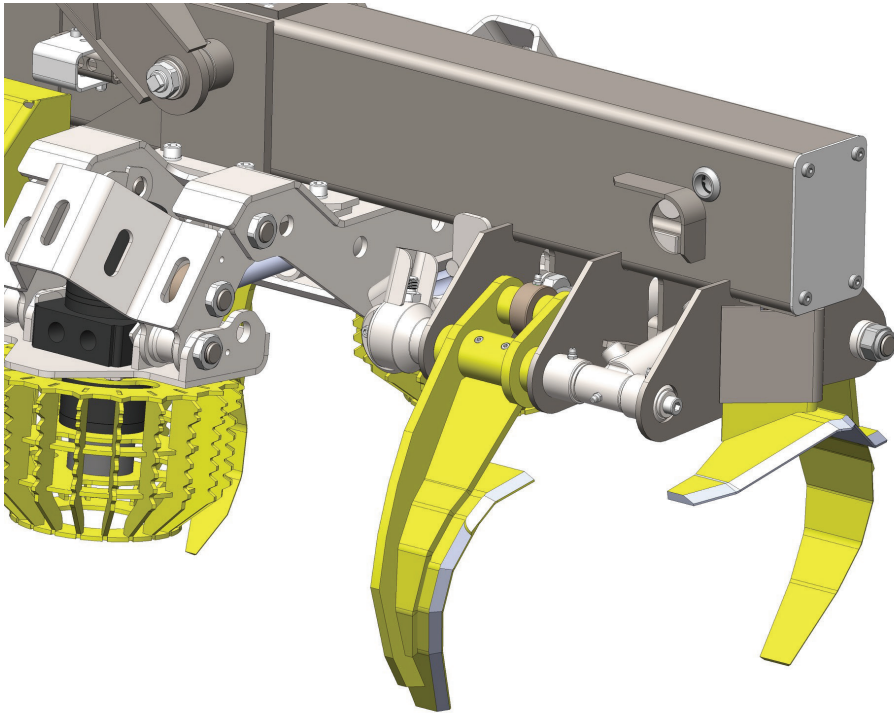

The knives

The knife profile is fitted to the optimal performance on stems of $\varnothing 10 - 20$ cm, but is still performing delimiting well from 25 cm down to abt. 3 cm.

All knives are movable. The top knife is spring loaded in order to follow small bends on the stems.

All knives are made from wear resistant (Hardox) steel. Main knives are pressure controlled with own pressure reducing valve at abt. 120-150 bar.

The main knife cylinders (2pcs) are fix mounted which ensures minimum movement of hoses.

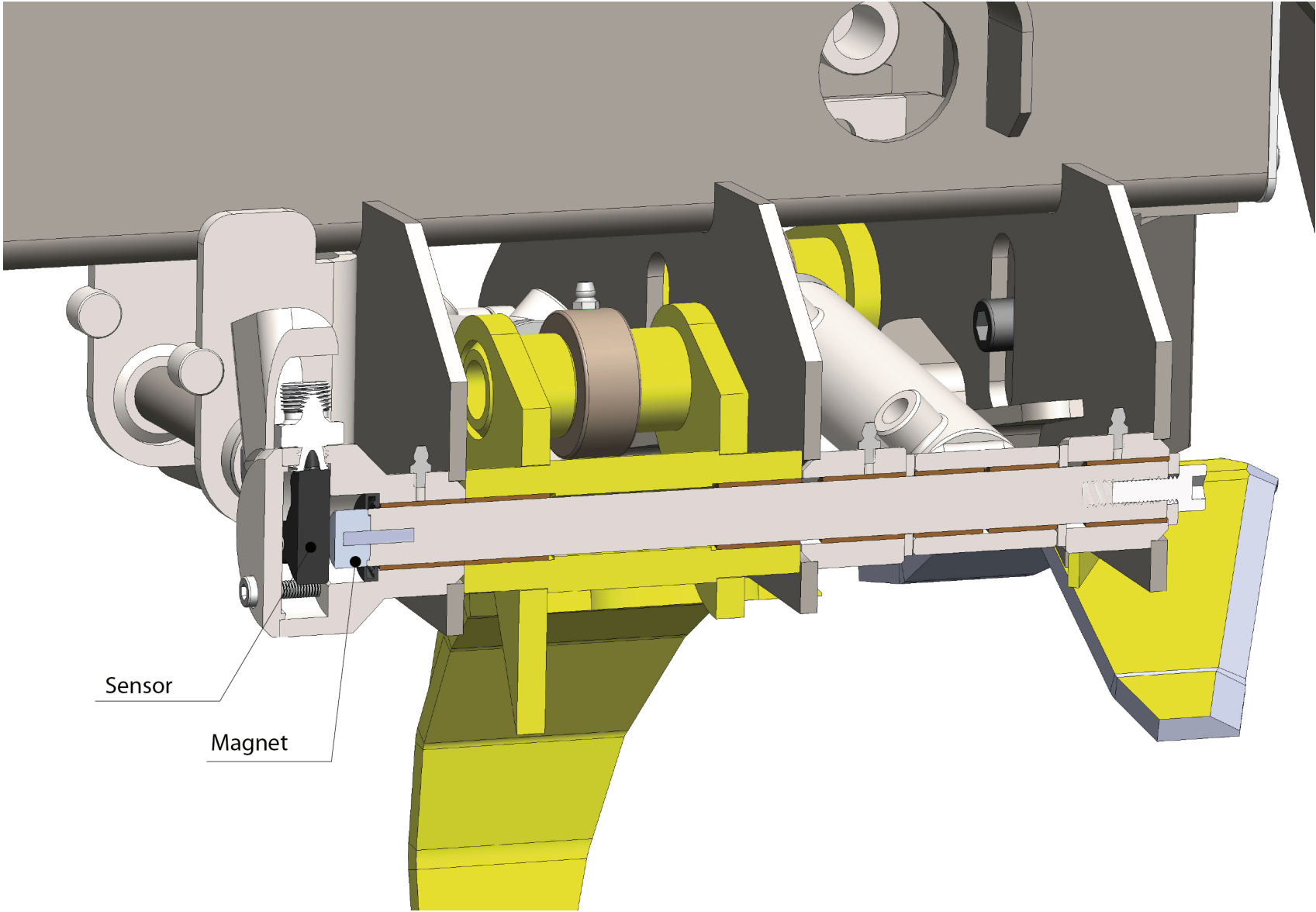



Diameter measurement

All ST50 harvester heads are prepared for diameter measuring. Measuring transducer is placed in the shaft end of left main knife. As its signal is magnetically transferred there are no moving parts making the system really reliable.

Technical features:

- Absolute sensor (HALL type)
- Magnet $\varnothing 20$ mm, sensing 2-4 mm
- resolution 12 bit, 180°
- Output 0,5 - 4,5V
- Operating voltage 5-30 VDC
- Operating temperature $-40 - +85^\circ\text{C}$
- Protection class IP67

Thanks to the sensor type (absolute) knife always knows in which position it is (angle). The measurement result can be calibrated in the control program (CCD/MID). This solution has a design protection.

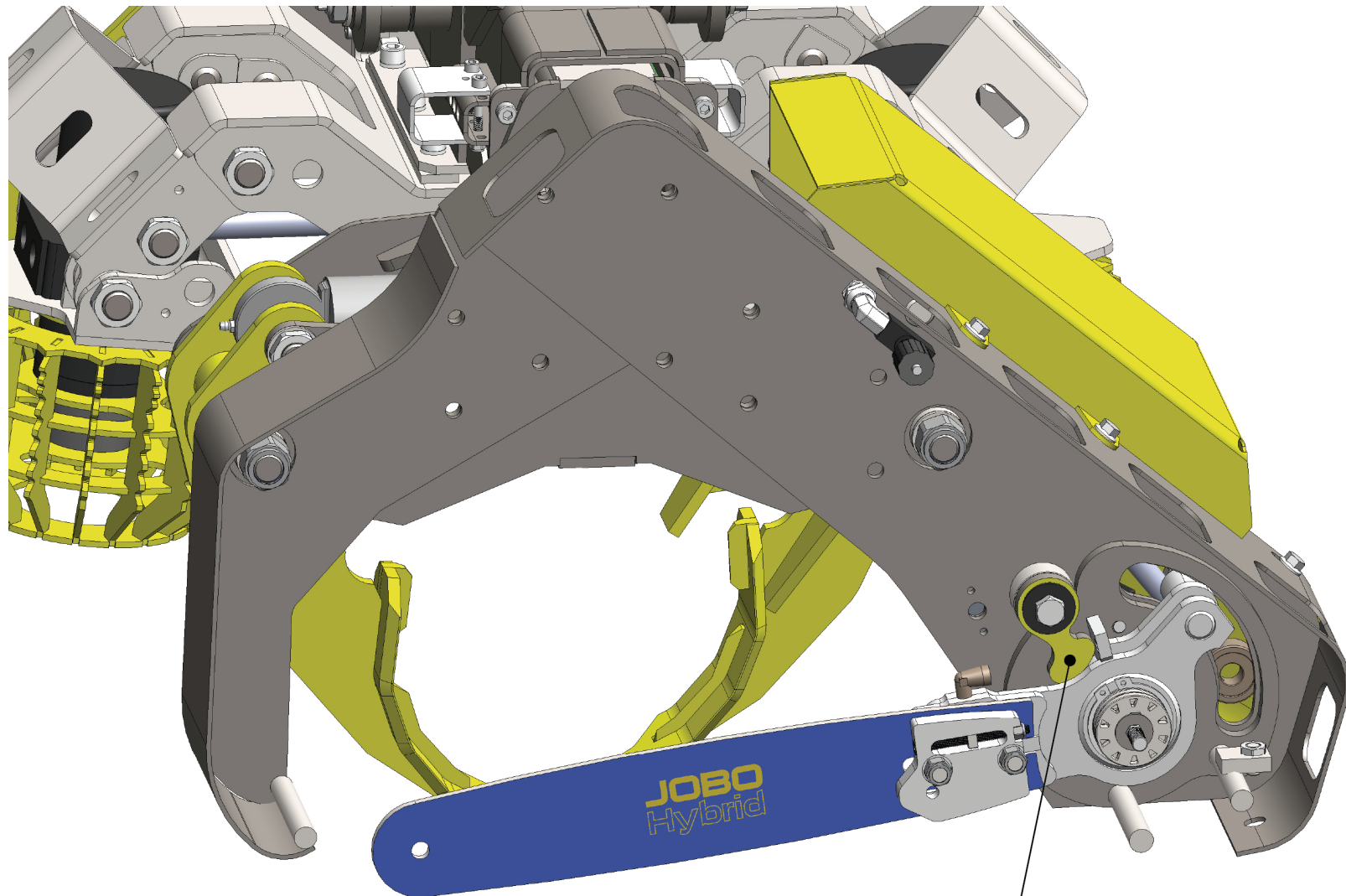

Genomsågnings stopp
Ohisahauksen esti
Saw limiter

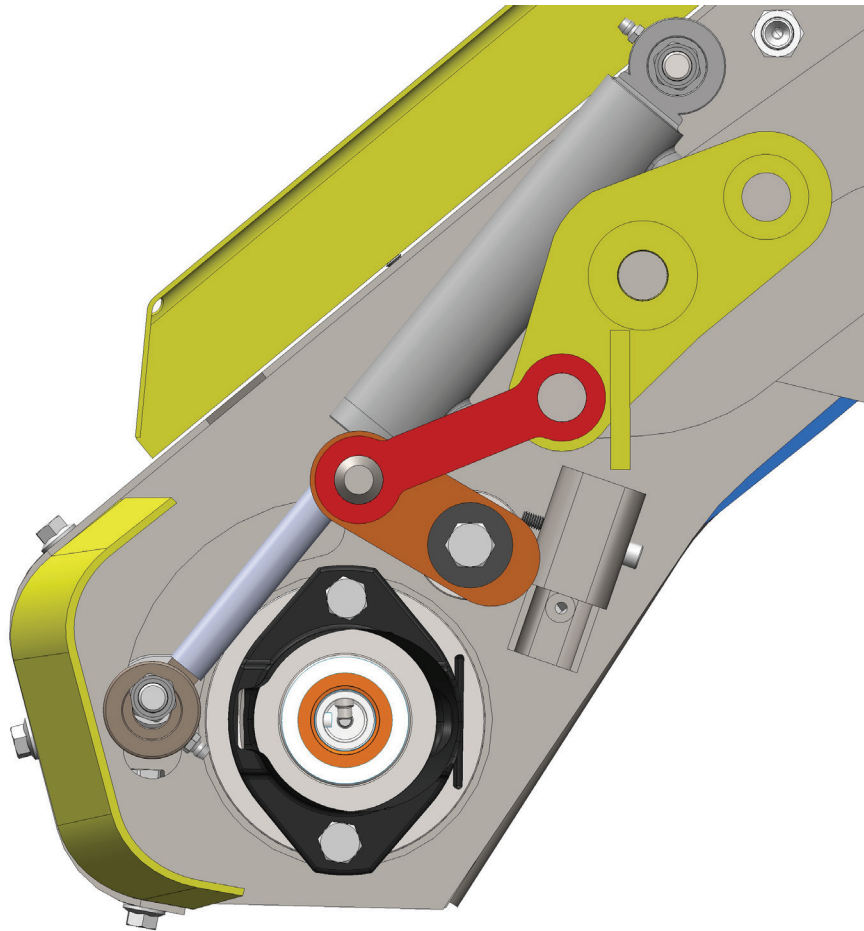

Saw limiter mechanism

A mechanical saw limiter is standard on all ST50- harvesters. The limiter is connected to the grip movement and it is adjusted so that saw will stop at a position of abt. 1/3 of width of the saw bar.

This is most valuable function when saw bar is not visible when felling (it is mostly hard to see what is behind).

This function also minimize the risk of saw bar passing the stem and gets stuck, or it accidentally hits a stone or nearby standing tree.

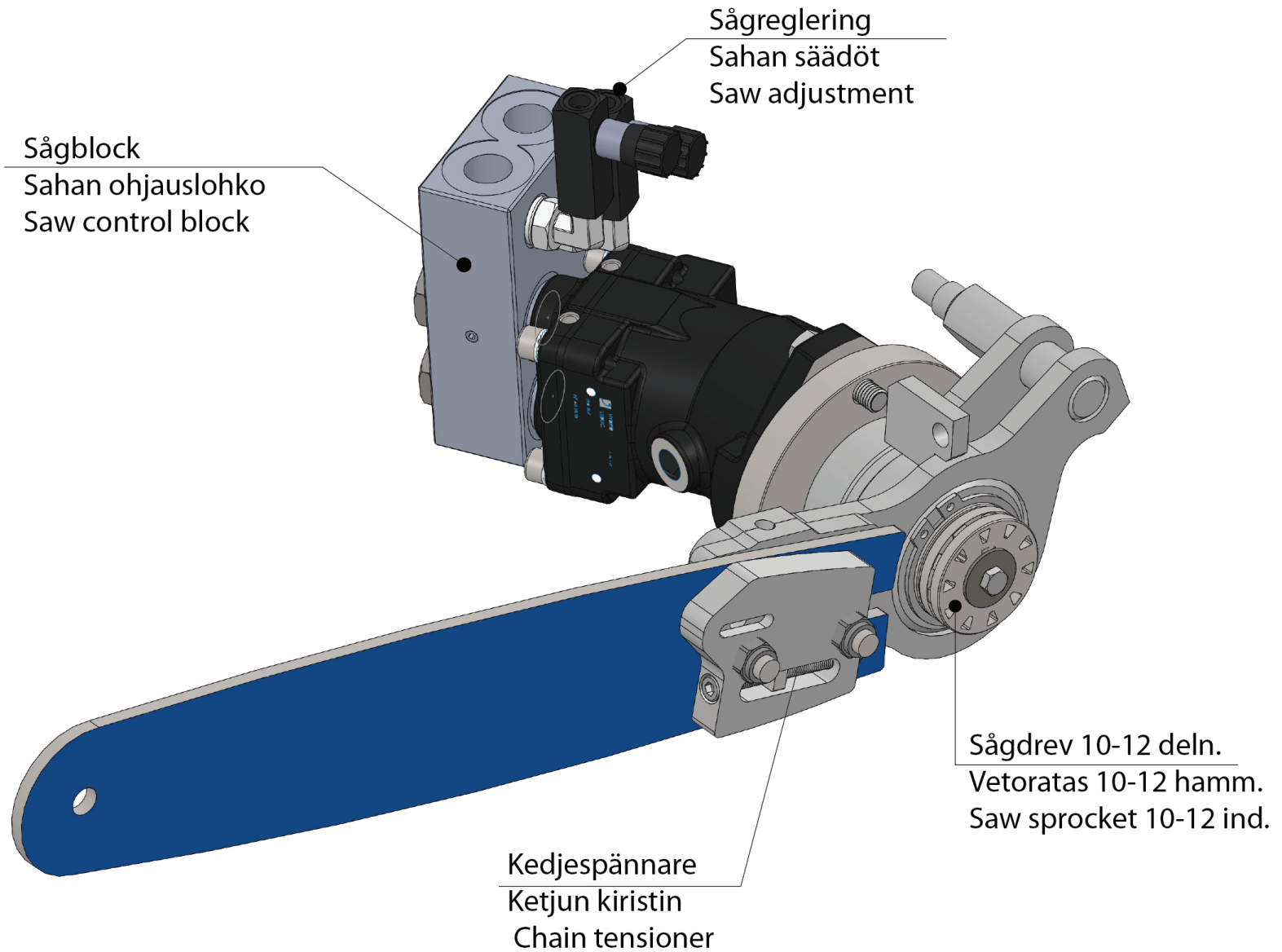



Saw control functions

An essential function of a harvester is how the saw is controlled. The saw motor must reach full speed before it hits the stem and during sawing feed pressure should be held at optimum saw effect.

It is also very important that the return pressure is not too high as that may tension the chain or put extra strain on the saw mechanism.

Technical features:

- Saw motor speed 6000 - 10000 rpm
- Chain speed max. abt 25 m/sec
- Power requirement 25 kW
- Feed pressure regulation
- Return pressure regulation

All functions are taken care of in the control block including valves and restrictors (see picture).

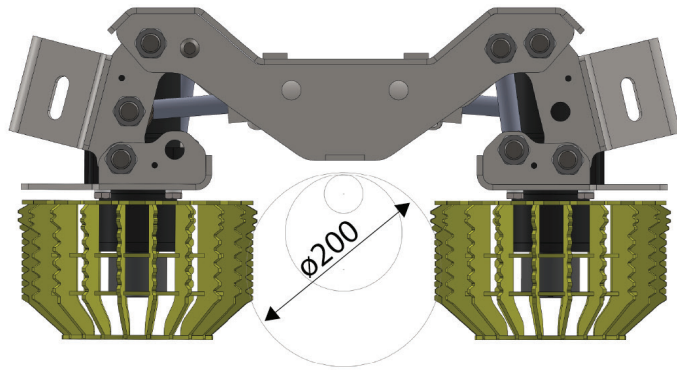

Fullt öppen $\varnothing 350$ mm
Täysin auki $\varnothing 350$ mm
Fully open $\varnothing 350$ mm

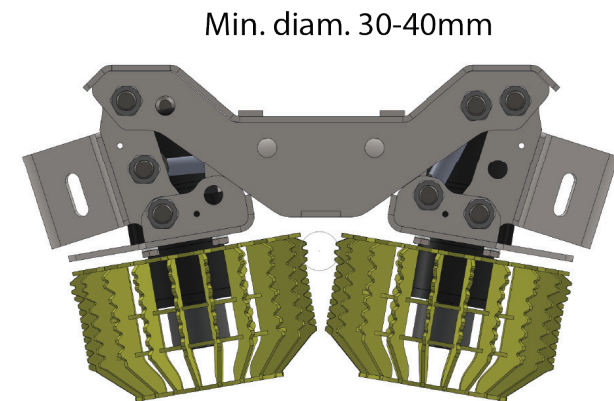
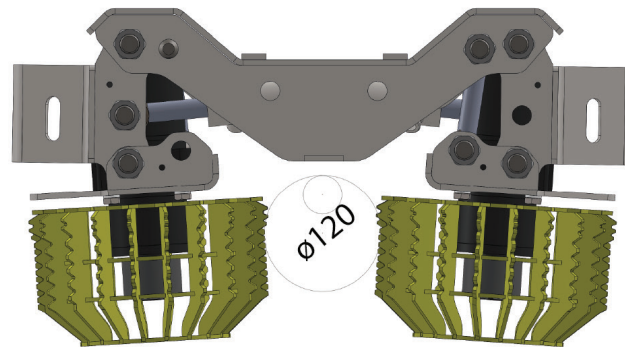

Min. diam. 30-40mm

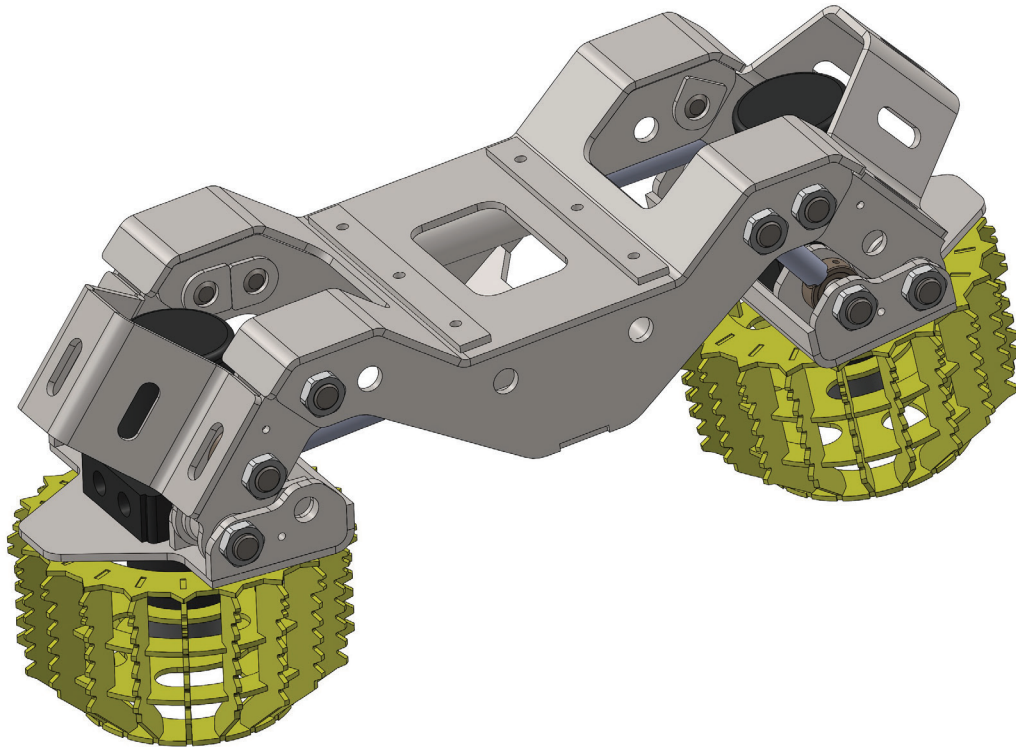

Feed rolls

In its COMBI version the ST50 is provided with welded feed rolls made in high strength steel. The light weight and open construction improves its self cleaning. Designed to be used on trees with few branches or only light branching. A secondary function of the Feed rolls is it provides support for a heavy tree in the MultiGrip position

Technical features:

- Roll diameter $\varnothing 220$ mm
- Roll hydraulic motors 2 x 200 cc
- Roll feed speed > 2 m/sec

ST50 PreCombi is a build which is prepared for retrofit of the roll system. All programs are as standard available.