

Hydraulic Pump

Hidrauliskie virzuļsūkņi

FR



Description

This line of fixed displacement bent axis piston pumps were developed with spherical head pistons. This provides extremely high performance and high pressure ratings on a long life span unit. Flow rates range from 10.5 to 29 GPM. These style pumps-motors are extremely efficient and very compact for easier and inexpensive installations. Bent Axis pumps-motors will mount directly to virtually any Bezares PTO in our extensive line.

Datos Principales Main Data

Tipo de Bomba Pump Type		FR 20	FR 30	FR 40	FR 50	FR 60	FR 80	FR 110
Codigo Part No.	Derecha CW	5040606	5040806	5041006	5047506	5041206	5041406	5041606
	Izquierda CCW	5040706	5040906	5041106	5048106	5041306	5041506	5041706
Desplazamiento Displacement (cm ³ /rev)		19	30.4	39.38	50	59.86	78.79	109.47
Presión Pressure bar (PSI)	máx. cont	350 (5076)						
	máx. peak (5sec)	400 (5800)						
Velocidad Speed r.p.m.	máx. cont	2200	2000	2000	1700	1700	1500	1400
	máx. int.	2800	2600	2600	2300	2300	2000	1900
Potencia Power kW	cont.	21	30	37	40	45	54	71
	máx.int	28	39	50	52	58	66	93
Peso Weight (kg)		7.6	7.7	9.5	10	10		15

FR 20/30

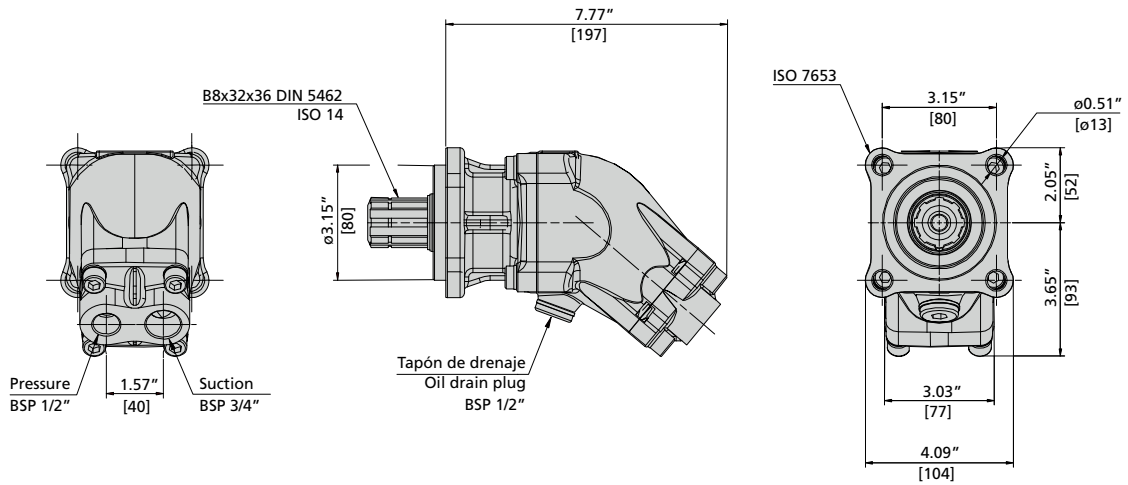

FR 40/50/60

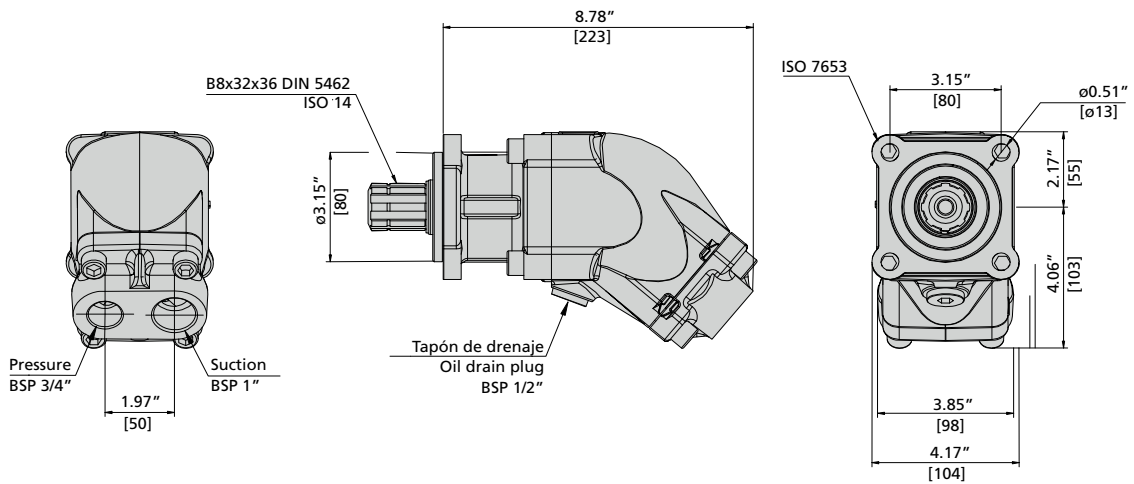

FR 80/110

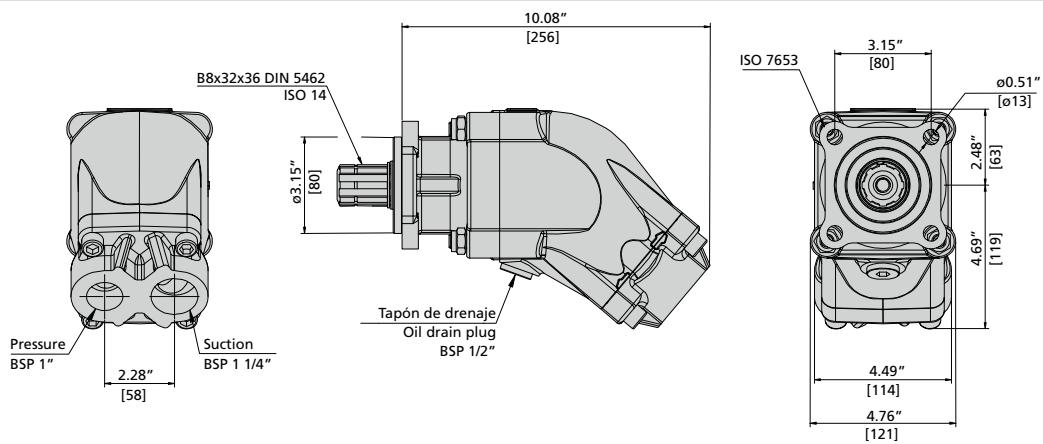

Hydraulic Pump

MR 40/60/80 MRAE 40/60/80

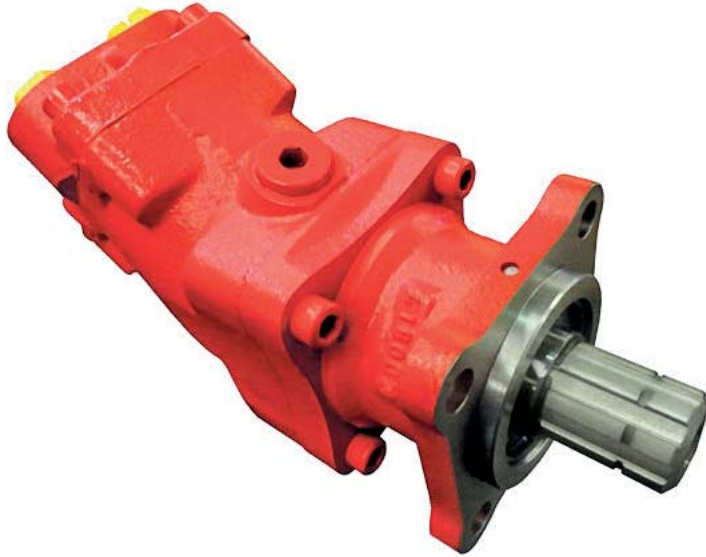

Description

This line of fixed displacement bent axis piston pumps were developed with spherical head pistons. Designed for medium/high pressure applications. Due to its reduced dimensions this pump is allowed to mount in small spaces.

Datos Principales Main Data

Tipo de Bomba Pump Type		MR 40	MR 60	MR 80	MR 110	
Codigo Part Number	DIN 5462 (MR)	Derecha CW	5050006	5050106	5051306	5051906
		Izquierda CCW	5050506	5050606	5051406	5052906
	DIN 9611 (MRAE)	Derecha CW	5052206	5050706	5051506	-
		Izquierda CCW	5052306	5052106	5051606	-
Desplazamiento Displacement (cm ³ /rev)		39.38	59.86	78	109.47	
Presión Pressure bar (PSI)	máx. cont (P1)	300 (4350)	300 (4350)	250 (3625)	300 (4350)	
	máx. peak (5 sec) (P3)	350 (5075)	350 (5075)	300 (4350)	350 (5075)	
Velocidad Speed r.p.m.	max. cont	1900	1600	1500*	1400*	
	max. int.	2400	2200	1900*	1800*	
Potencia Power kW	max. cont.	30	36	45	60	
	max. int	42	52	66	80	
Peso Weight (kg)		9.5	10	10	15	

* Con manguera de aspiración Ø2" como mínimo With minimum suction pipe of Ø2"

Hydraulic Pump

MR 40/60/80

MRAE 40/60/80

MR 40/60/80

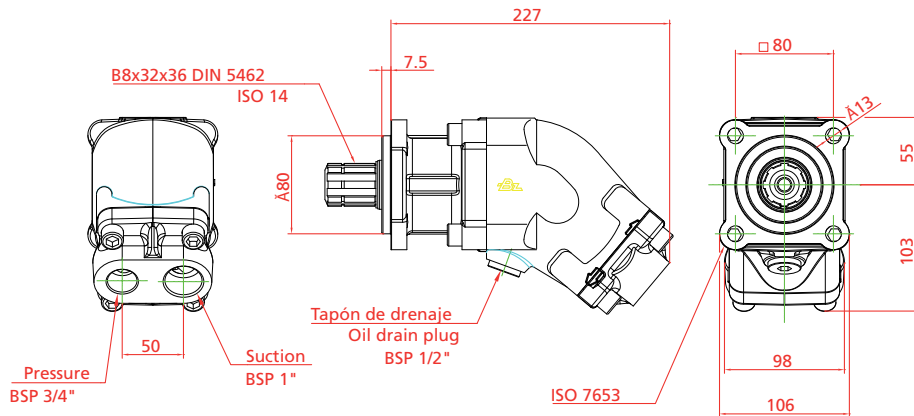

BOMBA MRAE - EJE AGRICOLA MRAE PUMP - AGRICULTURE SHAFT

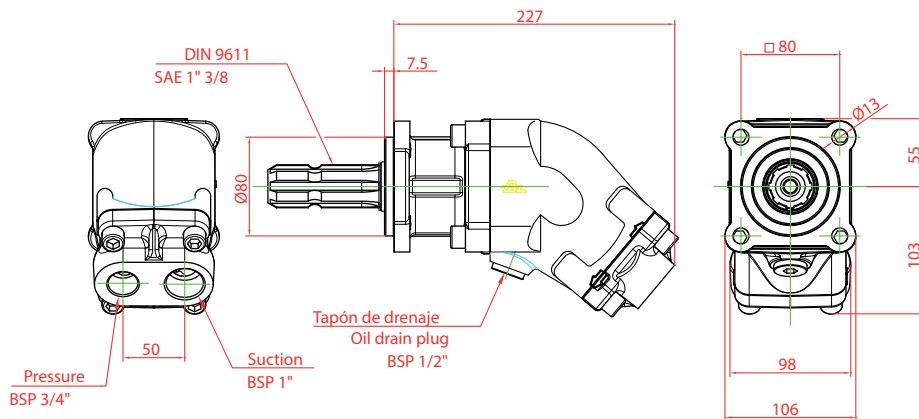

MR 110

