

VIPER VPH 3-2300 Pro Screen

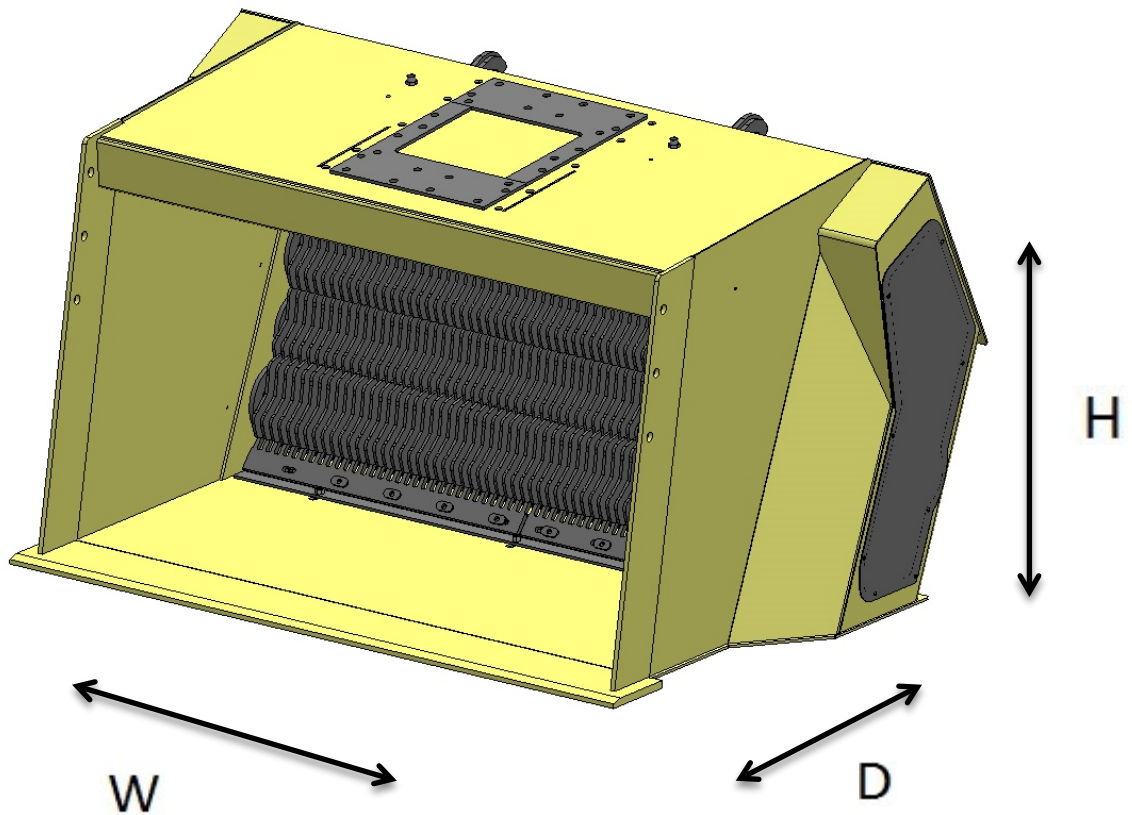

INFORMATION	www.vipermetal.fi
Widht, bucket [mm] (W)	2650
Widht, axel [mm]	2150
Depth [mm] (D)	1750
Height [mm] (H)	1400
Weight [kg]	2800
Screening area [m ²]	2
Volume ISO [m ³]	3,5
Volume SAE [m ³]	4,1
Recommended excavator (tons)	26-35
Recommended wheel loader (tons)	18-25
Grain size [mm]	18, 25, 35
Recommended Oil flow [l/min]	170-250
Recommended Oil pressure [bar]	200/350

All rights to change without prior notice received