



REPARK
WWW.REPARK.LV



rev 1.0

DATA SHEET

HYDRAULIC PISTON COMPRESSORS



HK 450 /8-14

HK 1000 /12-35

HYDRAULIC PISTON COMPRESSOR

DYNASET HK hydraulic piston compressors are compact and integrated all-in-one units, especially designed for mobile installation. The only power source needed is a hydraulic system of base machine which provides compressor the required hydraulic flow and pressure.

HK compressor converts the hydraulic power into high quality compressed air and it can be installed in almost any working machine. HK compressors are used to power for example pneumatic tools, filling tires and cleaning equipment.

The trouble free hydraulic compressor starts reliably and needs no extra fuel. It will serve a long time – with far less need for maintenance compared to a towed compressor unit of same power level.

HK compressors are designed to meet regular modern compressed air demands.

DIMENSIONS

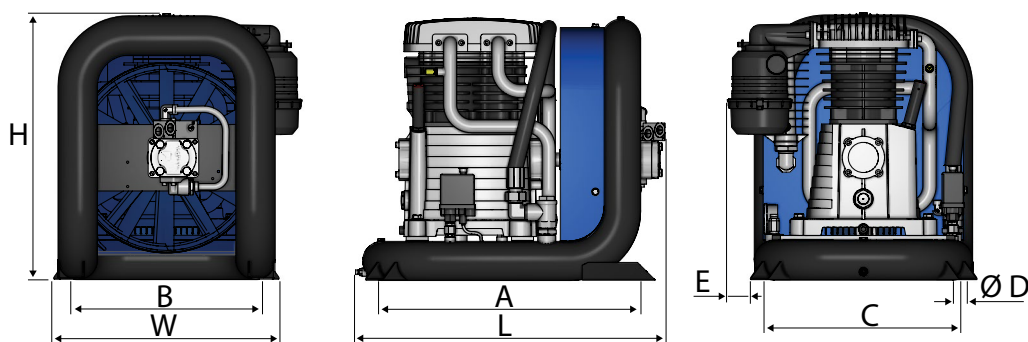

MODEL	DIMENSIONS, mm (in)								WEIGHT
	L	W	H	A	B	C	D	E	kg (lbs)
HK 450 /8-14	530 (20.9)	430 (16.9)	460 (18.1)	370 (14.7)	340 (13.4)	340 (13.4)	11 (0.43)	-	35 (77.2)
HK 1000 /12-35	725 (28.5)	490 (19.3)	600 (23.6)	610 (24.0)	430 (16.9)	445 (17.5)	13 (0.51)	55 (2.16)	80 (176.4)

PARAMETERS

		HK 450 /8-14	HK 1000 /12-35
DISCHARGE CHARACTERISTICS			
Flow rate max. at ref. conditions *	l/min (gal)	450 (118.9)	1000 (264.2)
Pressure max.	bar (psi)	8 (116)	12 (174)
Compressed air connection	AP	BSP 1/2"	BSP 1"
Frame reservoir	l (gal)	4,27 (1.13)	14 (3.70)
HYDRAULIC POWER REQUIREMENTS			
Oil flow min.	l/min (gal)	10 (2.64)	12 (3.17)
Oil flow nom.	l/min (gal)	15 (3.96)	35 (9.25)
Oil flow max.	l/min (gal)	35 (9.25)	50 (13.20)
Pressure at nominal flow	bar (psi)	130 (18.5)	210 (30.6)
Pressure max.	bar (psi)	210 (30.6)	230 (33.6)
Pressure when unloaded	bar (psi)	67 (972)	100 (14.0)
HYDRAULIC FLUID REQUIREMENTS			
Viscosity	cSt	10-200 / optimum 25-35	
Temperature **	° C (° F)	max. 70 (158)	
Filter ratio	µm	25 or better	
Cooling capacity requirement **	kW	2	4

Gallons are U.S. liquid gallons

* According to ISO 1217 (19.6) at discharge pressure of 6 bar

** Depending on hydraulic fluid.

*** Minimum oil cooling capacity for HK compressor on base machine.

CONNECTION PORTS

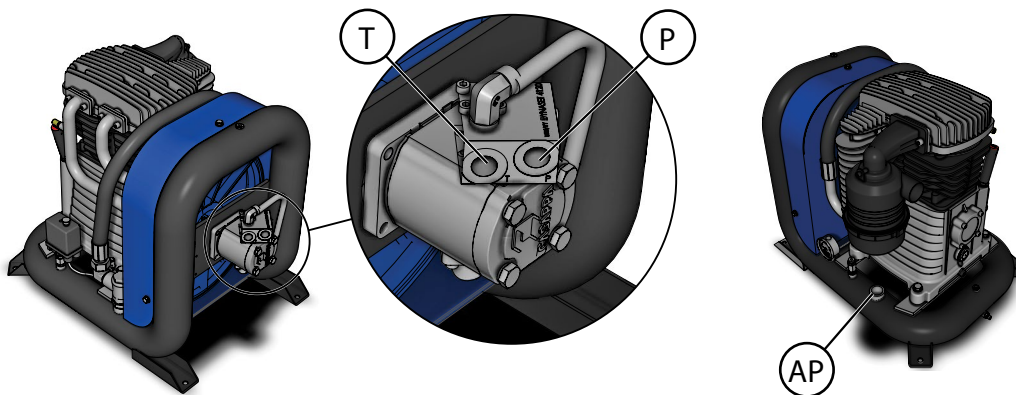

MODEL	PRESSURE LINE	RETURN LINE	AIR OUTPUT
	P	T	AP
HK 450 /8-14	BSP 1/2"	BSP 1/2"	BSP 1/2"
HK 1000 /12-35	BSP 1/2"	BSP 1/2"	BSP 1"