

THREE-PHASE ASYNCHRONOUS MOTORS
EFFICIENCY CLASS ACCORDING IEC 60034-30

1st EDITION

IE 1/IE 2-MS - IE 1/IE 2-EG Series

IE 1 "Standard efficiency"
IE 2 "High efficiency"





THREE-PHASE ASYNCHRONOUS MOTORS EFFICIENCY CLASS IN ACCORDANCE WITH IEC 60034-30

CONTENTS

Introduction.	
Standards and regulations	3
Mechanical and electrical tolerances	4
General Information.	
Main Features	5
Name plate	6
Connection schemes	6
Mechanical data.	
Types of construction	7
Bearings and Retainers. MS and MY Series Motors	8
Bearings and Retainers. EG Series Motors	9
Electrical Data.	
Nominal conditions of duty	10
Protection systems	11
Three-phase motors for frequency converter operation	11
Technical Data.	
Three-phase motors IE1-MS/EG 1 speed, 3000 rpm	12
Three-phase motors IE1-MS/EG 1 speed, 1500 rpm	13
Three-phase motors IE1-MS/EG 1 speed, 1000 rpm	14
Three-phase motors IE1-MS/EG 1 speed, 750 rpm	15
Single-phase motors MY 1 speed, 3000 rpm, 1500 rpm and 1000 rpm	16
Three-phase motors IE2-MS/EG 1 speed, 3000 rpm	17
Three-phase motors IE2-MS/EG 1 speed, 1500 rpm	18
Three-phase motors IE2-MS/EG 1 speed, 1000 rpm	19
Dimensions.	
Three-phase motors IE1-MS	20
Three-phase motors IE2-MS	21
Three-phase motors IE1/IE2-EG	22
Single-phase motors MY	23
Spare parts.	
Spare parts for MS series	24
Spare parts for EG series	25
Warranty.	
Warranties, Returns and Claims	26

Note: COSGRA reserves the right and the authority to modify the documentation and the products at any moment without prior notice.

INTRODUCTION



STANDARDS AND SPECIFICATIONS

CEMER motors comply with the relevant European and International norms and regulations, in particular with the following:

STANDARD TITLE	REFERENCE	
	EN Europe	IEC International
Electric rotating machines. Part 1: Rating and Performance characteristics.	EN 60034-1	IEC 60034-1
Electric rotating machines. Part 2-1: Methods for Determining Losses and Efficiency of Rotating Electrical Machinery from Tests.	EN 60034-2-1	IEC 60034-2-1
Electric rotating machines. Part 5: Classification of protection grades offered by protection enclosures.	EN 60034-5	IEC 60034-5
Electric rotating machines. Part 6: Cooling methods (IC code).	EN 60034-6	IEC 60034-6
Electric rotating machines. Part 7: Classification of construction types and Mounting Arrangements (IM code).	EN 60034-7	IEC 60034-7
Electric rotating machines. Part 8: Terminal markings and direction of rotation.	EN 60034-8	IEC 60034-8
Electric rotating machines. Part 9: Noise limits.	EN 60034-9	IEC 60034-9
Electric rotating machines. Part 11: Thermal protection.	-	IEC 60034-11
Electric rotating machines. Part 12: Starting performance of single-speed three-phase cage induction motors running at power supply tensions no greater than 660 V, 50 Hz.	EN 60034-12	IEC 60034-12
Electric rotating machines. Part 14: Mechanical vibration of certain machines with shaft heights 56 mm or higher - Measurement, evaluation and limits of vibration severity.	EN 60034-14	IEC 60034-14
Electric rotating machines. Part 30: Efficiency classes for three-phase induction cage motors of single speed (IE code).	-	IEC 60034-30
Thermal evaluation and designation for the electric isolation.	-	IEC 60085
Standard voltages IEC for electricity supply systems.	-	IEC 60038
Three-phase induction motors of general application with normalized powers and dimensions. Frame size designation from 56 to 315.	EN 50347	IEC 60072

INTRODUCTION



MECHANICAL TOLERANCE VALUES

Symbol	Short description	Tolerance
A	Between drilling centers on feet in an axial direction	± 1 mm
AB, AC	Maximum motor width (without terminal box)	+ 2 %
B	Between drilling centers on feet in a transversal direction	± 1 mm
C	From the center of the first foot hole to shaft flange	± 3 mm
D	Outer shaft diameter	k6 up to 48 mm m6 from 55 mm
E	Shaft diameter < than 55 mm Shaft diameter > than 60 mm	- 0.3 mm + 0.5 mm
F	Cotter width	h9
GA	Inferior shaft plan to superior cotter plan	+ 0.2 mm
H	Height from shaft center to feet base	- 0.5 \leq 250 mm - 1 \geq 280 mm
HD	Total height (from lowest point to highest point)	+ 2 %
K, S	Diameter of fixation holes, feet or flange	+ 3 %
L	Total motor length	+ 1 %
M	Between centers of flange fixation drilling holes	± 0.8 mm
N	Diameter of flange rim	j6 up to 230 mm h6 from 250 mm
P	Outer flange diameter	± 1 mm
	Highlight shaft to flange plan, with blocked bearing	± 0.5 mm
	Highlight shaft to flange plan	± 3 mm
m	Motor weight	From - 5 a + 10 %

ELECTRICAL TOLERANCE VALUES

Electrical parameters. In compliance with EN 60034-1 standard:

Efficiency (η) (Indirect measurement)	- 0.15 (1- η) for Nominal Power $P_N \leq 150$ kW - 0.1 (1- η) for $P_N > 150$ kW
Power factor (Cos φ)	$\frac{1-\cos\varphi}{6}$ minimum 0.02 maximum 0.07
Slippage (rpm) (At nominal temperature and load)	$\pm 20\%$ for $P_N \geq 1$ kW $\pm 30\%$ for $P_N < 1$ kW
Intensity at start (I_A)	+ 20% (without lower limit)
Torque at start (M_A)	-15% and +25%
Nominal torque (M_k) (maximum)	-10% (for this M_k value / M_n value must be of at least 1.6)
Minimum torque (M_s)	-15%
Moment of inertia (J)	$\pm 10\%$
Sound level (sound pressure)	+3 dB (A)

GENERAL INFORMATION



MAIN FEATURES

CEMER asynchronous three-phase and mono-phase motors have the following features, designed in accordance with IEC 60034, IEC 60038, IEC 60072; frame sizes 56 - 355; power 0,06 - 315 kW, valid for continuous operation (S1) at nominal voltage and frequency values; as well as for a maximum room temperature of 40°C, and at a maximum altitude of 1000 m. For single speed 2, 4, 6 and 8 pole motors at 230/400 V or 400/690 V, 50 Hz and 230 V 50 Hz. Class F isolating, and class B heating temperature. IP 55 protection, which prevents penetration of powders and water jets from all directions.

Part	Material	MS / MY Series	EG Series
Frame	Aluminum (MS MY series) Cast Iron (EG series)	Pressure cast aluminum Removable feet Eyebolt frame \geq 100 Ground connection	Cast iron Eyebolt Ground connection
Shields and Flanges	Aluminum (MS MY series) Cast iron (EG series)	Pressure cast aluminum Steel insertion on bearing housing	Cast iron Greaser
Stator	Cold laminated magnetic sheets Electrolytic copper	Made with vacuum double impregnation and pressurized with synthetic resins (VIP)	Produced with vacuum double impregnation and pressurized with synthetic resins (VIP) PTC thermistors
Terminal box	Aluminum (MS MY series) Cast iron (EG series)	90 ° adjustable in the 4 positions Equipped with glands Internal ground connection	90 ° adjustable in the 4 positions Equipped with glands Internal ground connection
Rotor	Cold laminated magnetic sheet Aluminum	Dynamic balancing with half key Hot mounting on the shaft	Dynamic balancing with half key Hot mounting on the shaft with driving key
Shaft	Steel	Front threaded hole Rounded key	Front threaded hole Rounded key
Bearings		Ball bearings with twin sealing, live lubricated Pre-loaded on shaft side	Ball bearings with twin sealing, live lubricated Pre-loaded on shaft side
Retainers	Synthetic rubber	Retainers on each sides for all sizes	Retainers on each sides for all sizes
Fan	Thermoplastic or aluminum (option)	Radial bidirectional blades	Radial bidirectional blades
Fan cover	Steel sheet	V1 position (vertical B5 shaft to down) with drain cover (option)	V1 position (vertical B5 shaft to down) with drain cover (option)
Painting	Epoxy paint	Blue color, RAL 5010 (MS series) Black color, RAL 9005 (MY series)	Blue color, RAL 5010

GENERAL INFORMATION



SPECIFICATION PLATE

Each motor is identified by a specification plate which shows all data required by the IEC 60034-30:2008 standard. The nameplate is made of aluminum or steel depending on the series, and is located on lateral side or on the frame's motor top.

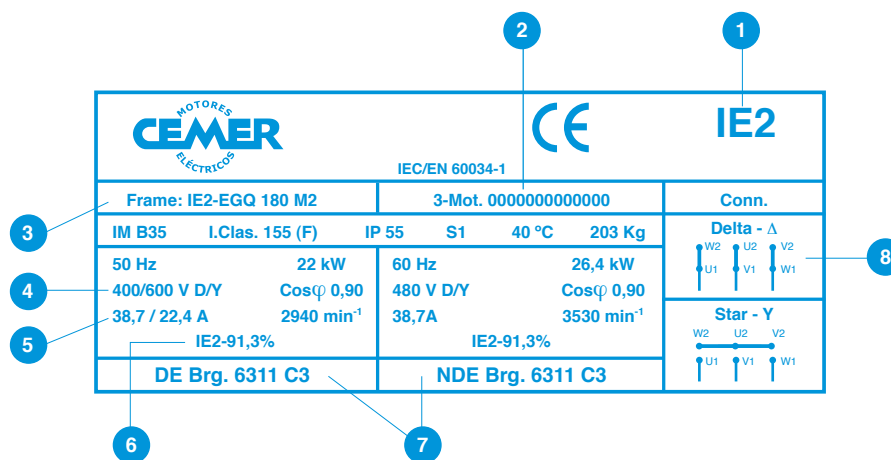

- 1 Efficiency class logo (IE1 or IE2)
- 2 Serial number
- 3 Type (IE2-EGQ 180M 2): efficiency class (IE2), serial (EGQ), frame size (180M) and poles (2)
- 4 Nominal voltage at 50 Hz
- 5 Nominal intensity at 50 Hz
- 6 Class of efficiency IE and nominal efficiency with 100% loading at 50 Hz
- 7 Type of bearings
- 8 Connection diagram (for motors with frame size ≥ 160)

CONNECTION DIAGRAM

Three-phase motor 1 speed

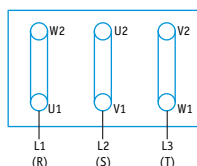

Low voltage (Δ)

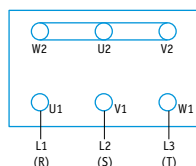

High voltage (Y)

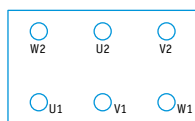

In case of use Y - Δ commutator without bridges, to connect according to supplier's diagram.

Starter (Y - Δ)

Single-phase motor

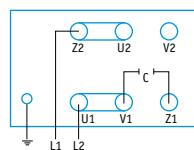

Clockwise

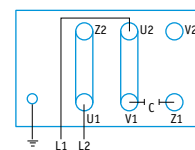

Anti clockwise

MECHANICAL FEATURES



TYPES OF CONSTRUCTION

CEMER motors in sizes 56 to 355 can be supplied in the construction types shown on the following table. Basic types of construction are designated in accordance with EN 60034-7. Motors in construction types IM B3, IM B5 or IM B14 can also be used in other mounting arrangements.

IM B3 in IM V5, IM V6, IM B6, IM B7, IM B8.

IM B35 in IM V15, IM V36, IM 2051, IM 2061, IM 2071.











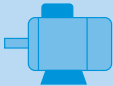
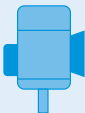

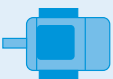

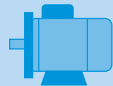

IM B34 in IM 2111, IM 2131, IM 2151, IM 2161, IM 2171.

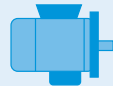
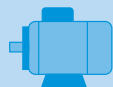
IM B5 in IM V1 and IM V3. (Through-hole THT flange).

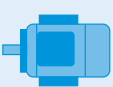
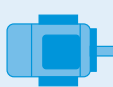
IM B14 in IM V18 and IM V19. (Flange with threaded holes).

For sizes 160 to 355 in any type of construction, please refer to the manufacturer, in particular forms IM V5, IM V6, IM B6, IM B7 and IM B8.

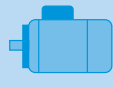
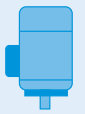
Forms IM B5 and IM V3 cannot be adapted to sizes 315 and 355. For size 280 please refer to the manufacturer.

Basic construction types			Other construction types		
IM B3 IM 1001 	IM V5 IM 1011 	IM V6 IM 1031 	IM B6 IM 1051 	IM B7 IM 1061 	IM B8 IM 1071 
IM B35 IM 2001 	IM V15 IM 2011 	IM V36 IM 2031 	IM 2051 	IM 2061 	IM 2071 
IM B34 IM 2101 	IM 2111 	IM 2131 	IM 2151 	IM 2161 	IM 2171 
IM B5 IM 3001 	IM V1 IM 3011 	IM V3 IM 3031 			
IM B14 IM 3601 	IM V18 IM 3611 	IM V19 IM 3631 			

MECHANICAL FEATURES



Serial motors MS /MY

BEARINGS

MS/MY motor series are produced as standard with rigid ball bearings with double rubber sealing on each side, they are lubricated for life, so are free maintained.

Motor		Bearing	
Frame Size	Poles	D-end	N-end
56	2-4-6-8	6201 2RS C3	6201 2RS C3
63	2-4-6-8	6201 2RS C3	6201 2RS C3
71	2-4-6-8	6202 2RS C3	6202 2RS C3
80	2-4-6-8	6204 2RS C3	6204 2RS C3
90	2-4-6-8	6205 2RS C3	6205 2RS C3 (6204 2RS C3*)
100	2-4-6-8	6206 2RS C3	6206 2RS C3
112	2-4-6-8	6306 2RS C3	6306 2RS C3
132	2-4-6-8	6308 2RS C3	6308 2RS C3
160	2-4-6-8	6309 2RS C3	6309 2RS C3

* This shows bearing reference for three-phase motors series IE1-MSL.

RETAINERS

MS/MY series use radial shaft double-lib spring-loaded retainers in order to improve motor enclosure efficiency.

Motor		Retainers	
Size	Poles	Front	Rear
56	2-4-6-8	12x22x5	12x22x5
63	2-4-6-8	12x24x5	12x24x5
71	2-4-6-8	15x25x7	15x25x7
80	2-4-6-8	20x34x7	20x34x7
90	2-4-6-8	25x37x7	25x37x7 (20x34x7*)
100	2-4-6-8	30x44x7	30x44x7
112	2-4-6-8	30x44x7	30x44x7
132	2-4-6-8	40x58x7	40x58x7
160	2-4-6-8	45x65x8	45x65x8

* This shows bearing reference for three-phase motors series IE1-MSL.

Note: The dimensions of bearings and retainers are not restricted to the series, for more information please ask.

MECHANICAL FEATURES



Serial motors EG

BEARINGS

The bearings are rigid on one race and they are open. Lithium-based bearing-grade grease must be used. EG serie cast-iron motors come with an external re-greasing device.

Motor		Bearing		
Frame size	Poles	D-end	N-end	Greasing hours/cm ³ .
160	2-4-6-8	6309 C3	6309 C3	2000 - 4000 / 20-20
180	2-4-6-8	6311 C3	6311 C3	2000 - 4000 / 23-23
200	2-4-6-8	6312 C3	6312 C3	2000 - 4000 / 31-31
225	2	6312 C3	6312 C3	2000 / 31-31
	4-6-8	6313 C3	6312 C3	4000 / 35-31
250	2	6313 C3	6313 C3	2000 / 35-35
	4-6-8	6314 C3	6313 C3	4000 / 41-35
280	2	6314 C3	6314 C3	2000 / 41-41
	4-6-8	6317 C3	6314 C3	4000 / 57-41
315	2	6317 C3	6317 C3	2000 / 57-57
	2	6317 C3	7317 ⁽¹⁾	2000 / 57-57
	4-6-8	6319 C3	6319 C3	4000 / 64-64
	4-6-8	6319 C3	7319 ⁽¹⁾	4000 / 64-64
	2	6319 C3	6319 C3	2000 / 64-64
355	2	6319 C3	7319 ⁽¹⁾	2000 / 64-64
	4-6-8	NU 322	6322 C3	3000 / 78-78
	4-6-8	NU 322	7322 ⁽¹⁾	3000 / 78-78

⁽¹⁾ Bearing type for vertical position motor.

TRANSMISSIONS

The correct selection of transmission components is essential for correct motor behavior. Please ask your pulley, belt and coupling supplier, or send an inquiry to our own technical department.

IMPORTANT NOTICE. Cylindrical roller bearings (NU) must always be subjected to at least 25% of their maximal radial load for correct motor behavior. In many cases the weight of the element supported by the bearing, including the external forces, is greater than the minimum required loading.

RETAINERS

EG series uses radial-shaft spring-loaded retainers with double lip in order to improve motor obturation efficiency.

Motor		Retainer	
Frame size	Poles	D-end	N-end
160	2-4-6-8	45x62x8	45x62x8
180	2-4-6-8	55x72x8	55x72x8
200	2-4-6-8	60x80x8	60x80x8
225	2	65x85x10	60x80x8
	4-6-8	65x90x10	60x80x8
250	2-4-6-8	70x90x10	65x85x10
280	2	70x90x10	70x90x10
	4-6-8	85x110x12	70x90x10
315	2	85x110x12	85x110x12
	4-6-8	95x120x12	95x120x12

Note: The dimensions of the bearings and the retainers are not binding to the series. For more information, please ask.

ELECTRICAL FEATURES



NOMINAL OPERATION CONDITIONS

Power

Nominal power values shown in this catalogue are compliant with EN 60034-1 standards, i.e. for temperatures up to 40°C and altitudes ≤ 1,000 m above sea level. The admissible overloads are 10% for the maximum temperature of 40 °C or the nominal power up to 2,500 metres above sea level.

In rooms exceeding the maximum stated temperature or at altitudes greater than 1,000 m above sea level, the motors can be operated as long as nominal power is reduced according to the following tables:

Room temperature °C	40	45	50	55	60			
Power %	100	97	93	87	82			
Altitude in meters above sea level		1000	1500	2000	2500	3000	3500	4000
Power %		100	98	95	91	87	83	78

Power and frequencies

Motors are designed to be able to operate at nominal conditions of power and frequency, within the tolerances shown in the diagram.

Motors can operate within the normal use area, zone A, with no decrease in nominal power with voltage variations of ± 5% on the design values and within ± 2% frequency variation.

In addition, motors can also operate within the restricted use area, zone B, within ± 10 % voltage variations and ± 3% frequency variations, always subject to the requirements of standard 60034-1.

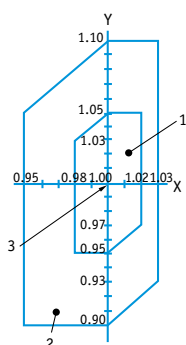

1. Zone A, normal-use area
2. Zone B, restricted-use area.
3. Design point, nominal features.

X = Frequency ratio, f/f_N

$$f/f_N = \frac{\text{Operation frequency}}{\text{Nominal frequency}}$$

Y = Tension ratio, U/U_N

$$U/U_N = \frac{\text{Operation voltage}}{\text{Nominal voltage}}$$

Basic version motors are delivered with the following voltage and frequency values:

230/400 V	Δ/Y	50 Hz
400/690 V	Δ/Y	50 Hz
690 V	Δ	50 Hz
480 V	Δ ó Y	60 Hz

Special frequencies and voltages can be delivered under special order.

Overload capacity

In accordance with standard EN 60034-1, all motors can be subject to the following overload conditions according to nominal frequency and voltage values:

- 1.5 times the nominal intensity for 2 minutes.
- 1.6 times the nominal torque for 15 seconds ($1.5 \times I_A/I_N < 4.5$).

ELECTRICAL FEATURES



PROTECTION SYSTEMS

On request, the following motor protection systems can be supplied:

- PTC temperature probes, thermistors inserted in the winding.
- Bimetallic temperature probes, usually NC encased, or usually NO open.
- Pt100 temperature probes in the bearings.
- Heating resistors in the winding.

ASYNCHRONOUS MOTORS TO BE USED WITH A FREQUENCY CONVERTER

Every CEMER motor can be powered by a frequency converter, but always according to the following technical requirements:

If the customer does not take any precaution on the design of the electrical system, motors with regular insulation grade may fail and break down. Voltage peaks on the motor terminals may be of a very high amplitude and considerable length in time. Depending on the type, length and configuration of the motor winding, impulses can increase the voltage of the link converter by up to two times.

If the link voltage of the converter does not exceed 600V, CEMER motors can operate in conjunction with a converter supplied with a voltage of up to 420 V without the need of a rear filter. A star (Y) connection should be ordered for those motors.

From casings 280 and upwards, COSGRA recommends the use of an insulated bearing on side B (fan side) in order to avoid currents that can affect them.

Advice notices for the correct behavior operation of motors with a converter.

Motors are only a complex part of an electrically-actuated system. Modern motors and converters offer protection against thermal overload. However, they are not protected against excess voltage peaks on the motor terminals. Because of the actuation system, problems can be exacerbated in the absence of filters on the converter outlet, and/or excessive cabling length. This often causes serious damage to the insulation of the motor.

Several options exist to optimize the electrical actuation system:

- .- Filter circuits on the converter outlet (obturation, du/dt, sine).
- .- Motors with reinforced insulation systems.
- .- A combination of both of the above.

The person responsible for the specification must carefully select the various components of the system. It is their responsibility to ensure that the terminal voltage does not exceed permitted levels. This also includes selecting the motor insulation, always bearing in mind the effects of other components in the system.

Our technical department is highly specialized in these type of applications and are able to advise you on the correct selection of motor for each application.

ELECTRICAL DATA

Asynchronous three-phase motors, squirrel-case rotor.
External cooling IC 411, continuous service S1.
Isolating class 155(F), protection grade IP 55.

Aluminum motors **IE1-MS** series

Cast iron motors **IE1-EG** series

Synchronous speed 3000 rpm - 2 poles

400 V, 50 Hz

TYPE	Power		M _N N.m	n rpm	IE1 efficiency class EN 60034-2-1 100%	I _N 400 V A	I _A /I _N	Cosφ	M _A /M _N	M _K /M _N	J Kg·m ²	Noise level dB(A)	m Kg
	kW	CV											
MS 56 1-2	0.09	0.12	0.32	2710	53	0.36	4	0.72	2.2	2.3	0.00006	58	2.6
MS 56 2-2	0.12	0.17	0.42	2700	61	0.4	4	0.72	2.2	2.3	0.00008	58	3.0
• MS 56 3-2	0.18	0.25	0.63	2710	63	0.55	6	0.75	2.2	2.4	0.00010	61	4.0
MS 63 1-2	0.18	0.25	0.63	2710	63	0.55	6	0.75	2.2	2.4	0.00013	61	4.0
MS 63 2-2	0.25	0.33	0.88	2710	65	0.71	6	0.78	2.2	2.4	0.00015	61	4.2
• MS 63 3-2	0.37	0.5	1.30	2710	65	1.05	6	0.78	2.2	2.4	0.00017	62	4.7
MS 71 1-2	0.37	0.5	1.29	2730	70	0.97	6	0.79	2.2	2.4	0.00021	64	5.2
MS 71 2-2	0.55	0.75	1.90	2760	71	1.42	6	0.79	2.2	2.4	0.00027	64	6.0
• MS 71 3-2	0.75	1	2.62	2730	72	1.83	6	0.82	2.2	2.4	0.00033	65	7.0
IE1-MS 80 1-2	0.75	1	2.59	2770	73	1.77	6	0.84	2.2	2.4	0.00039	67	8.7
IE1-MS 80 2-2	1.1	1.5	3.79	2770	76.2	2.51	6	0.83	2.2	2.4	0.00051	67	10.0
• MS 80 3-2	1.5	2	5.12	2800	78.5	3.32	6	0.83	2.2	2.4	0.00068	70	11.2
IE1-MS 90 S-2	1.5	2	5.04	2840	78.5	3.28	6	0.84	2.2	2.4	0.00093	72	12.0
IE1-MS 90 L1-2	2.2	3	7.40	2840	81	4.61	6	0.85	2.2	2.4	0.00115	72	14.5
• MS 90 L2-2	3	4	10.09	2840	82.6	6.1	6	0.86	2.2	2.4	0.00142	74	15.0
IE1-MS 100 L1-2	3	4	10.09	2840	82.6	6.03	7	0.87	2.2	2.3	0.00211	76	20.0
• MS 100 L2-2	4	5.5	13.40	2850	84.2	7.88	7.5	0.87	2.2	2.3	0.00272	77	24.0
IE1-MS 112 M-2	4	5.5	13.26	2880	84.2	7.88	7.5	0.87	2.2	2.3	0.00317	77	26.0
• MS 112 L2-2	5.5	7.5	18.24	2880	85.7	10.5	7.5	0.88	2.2	2.3	0.00434	78	29.3
IE1-MS 132 S1-2	5.5	7.5	18.11	2900	85.7	10.5	7.5	0.88	2	2.2	0.00744	80	38.4
IE1-MS 132 S2-2	7.5	10	24.53	2920	87	14.1	7.5	0.88	2	2.2	0.00910	80	41.3
• MS 132 M1-2	9.2	12.5	29.99	2930	88	17.3	7.5	0.89	2	2.2	0.01072	81	48.2
• MS 132 M2-2	11	15	35.85	2930	88.4	20	7.5	0.90	2	2.2	0.01146	83	52.5
IE1-MS 160 M1-2	11	15	35.73	2940	88.4	20	7.5	0.90	2	2.2	0.02380	86	76.0
IE1-MS 160 M2-2	15	20	48.72	2940	89.4	26.6	7.5	0.91	2	2.2	0.03117	86	77.5
IE1-MS 160 L2-2	18.5	25	60.09	2940	90	32.6	7.5	0.91	2	2.2	0.03617	86	92.0
IE1-EG 160 M1-2	11	15	35.9	2930	88.4	21.2	7.5	0.89	2.2	2.3	0.0377	88	109
IE1-EG 160 M2-2	15	20	48.9	2930	89.4	28.6	7.5	0.89	2.2	2.3	0.0449	88	125
IE1-EG 160 L-2	18.5	25	60.3	2930	90	34.7	7.5	0.90	2.2	2.3	0.0550	88	147
IE1-EG 180 M-2	22	30	71.5	2940	90.5	41	7.5	0.90	2	2.3	0.0750	91	180
IE1-EG 200 L1-2	30	40	97.1	2950	91.4	55.4	7.5	0.90	2	2.3	0.1240	94	240
IE1-EG 200 L2-2	37	50	120	2950	92	67.9	7.5	0.90	2	2.3	0.1390	94	255
IE1-EG 225 M-2	45	60	145	2970	92.5	82.1	7.5	0.90	2	2.3	0.2330	94	309
IE1-EG 250 M-2	55	75	177	2970	93	99.8	7.5	0.90	2	2.3	0.3120	95	403
IE1-EG 280 S-2	75	100	241	2970	93.6	135	7.5	0.90	2	2.3	0.5790	96	572
IE1-EG 280 M-2	90	125	289	2970	93.9	160	7.5	0.91	2	2.3	0.6750	96	620
IE1-EG 315 S-2	110	150	353	2980	94	195	7.1	0.91	1.8	2.2	1.1800	98	980
IE1-EG 315 M-2	132	180	423	2980	94.5	233	7.1	0.91	1.8	2.2	1.8200	98	1080
IE1-EG 315 L1-2	160	220	513	2980	94.6	279	7.1	0.92	1.8	2.2	2.0800	101	1160
IE1-EG 315 L2-2	200	270	641	2980	94.8	348	7.1	0.92	1.8	2.2	2.4100	101	1190

• Reduced frame size.

* The electrical data are not restricted to the series, for more detailed information please ask. Data MSL Series and EGQ series.

ELECTRICAL DATA

Asynchronous three-phase motors, squirrel-case rotor.
External cooling IC 411, continuous service S1.
Isolating class 155(F), protection grade IP 55.

Aluminum motors **IE1-MS** series

Cast iron motors **IE1-EG** series

Synchronous speed 1500 rpm - 4 poles

400 V, 50 Hz

TYPE	Power		M _N N.m	n rpm	IE1 efficiency class EN 60034-2-1 100%	I _N 400 V A	I _A /I _N	Cosφ	M _A /M _N	M _K /M _N	J Kgm ²	Noise level dB(A)	m Kg
	kW	CV											
MS 56 1-4	0.06	0.08	0.42	1360	50	0.35	4	0.56	2.3	2.4	0.00009	50	2.9
MS 56 2-4	0.09	0.12	0.63	1360	52	0.45	4	0.59	2.3	2.4	0.00011	50	3.2
• MS 56 3-4	0.12	0.17	0.84	1360	52	0.55	4	0.64	2.2	2.4	0.00014	52	3.7
MS 63 1-4	0.12	0.17	0.84	1360	52	0.55	4	0.64	2.2	2.4	0.00016	52	3.7
MS 63 2-4	0.18	0.25	1.31	1310	57	0.7	4	0.65	2.2	2.4	0.00020	52	4.2
• MS 63 3-4	0.25	0.33	1.78	1340	60	0.91	4	0.66	2.2	2.2	0.00023	54	5.0
MS 71 1-4	0.25	0.33	1.77	1350	60	0.84	6	0.72	2.2	2.4	0.00058	55	5.0
MS 71 2-4	0.37	0.5	2.58	1370	65	1.11	6	0.74	2.2	2.4	0.00065	55	5.8
• MS 71 3-4	0.55	0.75	3.81	1380	66	1.6	6	0.75	2.2	2.4	0.00087	57	6.5
MS 80 1-4	0.55	0.75	3.83	1370	67	1.58	6	0.75	2.2	2.4	0.00124	58	8.1
IE1-MS 80 2-4	0.75	1	5.19	1380	72	1.93	6	0.78	2.2	2.4	0.00167	58	9.1
• MS 80 3-4	1.1	1.5	7.56	1390	76.2	2.67	6	0.78	2.2	2.4	0.00185	60	11.0
IE1-MS 90 S-4	1.1	1.5	7.50	1400	76.2	2.64	6	0.79	2.2	2.4	0.00168	61	11.7
IE1-MS 90 L1-4	1.5	2	10.23	1400	78.5	3.45	6	0.80	2.2	2.4	0.00217	61	14.4
• MS 90 L2-4	2.2	3	15.01	1400	81	4.9	7	0.80	2.2	2.4	0.00262	63	17.6
IE1-MS 100 L1-4	2.2	3	14.80	1420	81	4.84	7	0.81	2.2	2.3	0.00335	64	19.2
IE1-MS 100 L2-4	3	4	20.18	1420	82.6	6.47	7	0.81	2.2	2.3	0.00463	64	22.5
• MS 100 L3-4	4	5.5	26.71	1430	84.2	8.36	7	0.82	2.2	2.3	0.00508	65	27.3
IE1-MS 112 M-4	4	5.5	26.71	1430	84.2	8.26	7	0.83	2.2	2.2	0.00866	65	29.0
• MS 112 L-4	5.5	7.5	36.48	1440	85.7	11.2	7	0.83	2.2	2.2	0.00955	68	35.7
IE1-MS 132 S-4	5.5	7.5	36.22	1450	85.7	11	7	0.84	2.2	2.2	0.01803	71	39.0
IE1-MS 132 M-4	7.5	10	49.40	1450	87	14.6	7	0.85	2.2	2.2	0.02218	71	48.6
• MS 132 L1-4	9.2	12.5	60.18	1460	87.5	17.9	7.5	0.85	2.2	2.2	0.02436	74	56.5
• MS 132 L2-4	11	15	71.95	1460	88.4	20.9	7.5	0.86	2.2	2.2	0.02672	74	64
IE1-MS 160 M-4	11	15	71.95	1460	88.4	20.6	7	0.87	2.2	2.2	0.04575	75	73.0
IE1-MS 160 L-4	15	20	98.12	1460	88.4	28.2	7.5	0.87	2.2	2.2	0.05968	75	88.5
IE1-EG 160 M-4	11	15	72	1460	88.4	22.5	7	0.84	2.2	2.3	0.0747	80	118
IE1-EG 160 L-4	15	20	98.1	1460	89.4	30	7.5	0.85	2.2	2.3	0.0918	79	138
IE1-EG 180 M-4	18.5	25	120.2	1470	90	36.3	7.5	0.86	2.2	2.3	0.1390	80	182
IE1-EG 180 L-4	22	30	142.9	1470	90.5	43	7.5	0.86	2.2	2.3	0.1580	80	190
IE1-EG 200 L-4	30	40	194.9	1470	91.4	58	7.2	0.86	2.2	2.3	0.2620	83	243
IE1-EG 225 S-4	37	50	239	1480	92	70.2	7.2	0.87	2.2	2.3	0.4060	85	284
IE1-EG 225 M-4	45	60	290	1480	92.5	85	7.2	0.87	2.2	2.3	0.4690	84	320
IE1-EG 250 M-4	55	75	355	1480	93	103	7.2	0.87	2.2	2.3	0.6600	86	452
IE1-EG 280 S-4	75	100	484	1480	93.6	140	7.2	0.87	2.2	2.3	1.1200	89	562
IE1-EG 280 M-4	90	125	577	1490	93.9	167	7.2	0.87	2.2	2.3	1.4600	89	667
IE1-EG 315 S-4	110	150	705	1490	94.5	201	6.9	0.88	2.1	2.2	3.1100	96	1000
IE1-EG 315 M-4	132	180	846	1490	94.8	240	6.9	0.88	2.1	2.2	3.6200	96	1100
IE1-EG 315 L1-4	160	220	1026	1490	94.9	288	6.9	0.89	2.1	2.2	4.1300	100	1160
IE1-EG 315 L2-4	200	270	1282	1490	94.9	360	6.9	0.89	2.1	2.2	4.9400	100	1270
IE1-EG 355 M-4	250	340	1608	1485	95.2	443	6.9	0.90	2.1	2.2	5.6700	104	1700
IE1-EG 355 L2-4	315	430	2026	1485	95.2	559	6.9	0.90	2.1	2.2	6.6600	104	1850

• Reduced frame size.

* The electrical data are not restricted to the series, for more detailed information please ask. Data MSL Series and EGQ series.

ELECTRICAL DATA

Asynchronous three-phase motors, squirrel-case rotor.
External cooling IC 411, continuous service S1.
Isolating class 155(F), protection grade IP 55.

Aluminum motors **IE1-MS** series

Cast iron motors **IE1-EG** series

Synchronous speed 1000 rpm - 6 poles

400 V, 50 Hz

TYPE	Power		M _N N.m	n rpm	IE1 efficiency class EN 60034-2-1 100%	I _N 400 V A	I _A /I _N	Cosφ	M _A /M _N	M _K /M _N	J Kgm ²	Noise level dB(A)	m Kg
	kW	CV											
MS 63 1-6	0.09	0.12	1	840	42	0.51	3.5	0.61	2	2	0.00021	50	4.2
MS 63 2-6	0.12	0.17	1.3	850	45	0.62	3.5	0.62	2	2	0.00023	50	4.5
MS 71 1-6	0.18	0.25	2	880	56	0.7	4	0.66	1.6	1.7	0.00065	52	5.6
MS 71 2-6	0.25	0.33	2.7	900	59	0.87	4	0.70	2.1	2.2	0.00087	52	6.0
• MS 71 3-6	0.37	0.5	4	890	61	1.27	4	0.69	2	2.1	0.00108	54	6.8
MS 80 1-6	0.37	0.5	3.9	900	62	1.23	4	0.70	1.9	1.9	0.00140	56	8.1
MS 80 2-6	0.55	0.75	5.8	900	67	1.65	4	0.72	2	2.3	0.00186	56	9.6
• MS 80 3-6	0.75	1	8	900	68	2.21	4	0.72	2	2.3	0.00232	58	10.0
IE1-MS 90 S-6	0.75	1	7.8	920	69	2.18	5.5	0.72	2.2	2.2	0.00266	59	11.3
IE1-MS 90 L1-6	1.1	1.5	11.4	925	72	3.02	5.5	0.73	2.2	2.2	0.00350	59	14.4
• MS 90 L2-6	1.5	2	15.5	925	74	3.9	5.5	0.75	2	2.2	0.00625	60	15.5
IE1-MS 100 L1-6	1.5	2	15.2	945	74	3.85	6	0.76	2.2	2.2	0.00562	61	18.8
• MS 100 L2-6	2.2	3	22.1	950	77	5.43	6	0.76	2.2	2.2	0.01225	63	19.8
IE1-MS 112 M-6	2.2	3	22	955	78	5.36	6	0.76	2.2	2.2	0.01333	64	25.0
• MS 112 L-6	3	4	30.2	950	79	7.12	6	0.77	2.2	2.2	0.01800	64	30.0
IE1-MS 132 S-6	3	4	29.8	960	79	7.21	6.5	0.76	2	2	0.02187	64	35.0
IE1-MS 132 M1-6	4	5.5	39.8	960	80.5	9.44	6.5	0.76	2	2	0.02541	68	47.6
IE1-MS 132 M2-6	5.5	7.5	54.7	960	83	12.4	6.5	0.77	2	2	0.03068	68	50.7
• MS 132 L-6	7.5	10	74.6	960	85	16.5	6.5	0.77	2	2	0.03602	68	47.6
IE1-MS 160 M-6	7.5	10	74.6	960	86	15.7	6.5	0.80	2	2.2	0.06927	68	70.0
IE1-MS 160 L-6	11	15	109.4	960	87.5	23	6.5	0.79	2	2.2	0.12674	73	87.0
IE1-EG 160 M-6	7.5	10	73.8	970	86	17	6.5	0.77	2	2.1	0.0881	80	119
IE1-EG 160 L-6	11	15	108	970	87.5	24.5	6.5	0.78	2	2.1	0.1160	80	147
IE1-EG 180 L-6	15	20	148	970	89	31.6	7	0.81	2	2.1	0.2070	79	195
IE1-EG 200 L1-6	18.5	25	182	970	90	38.6	7	0.81	2.1	2.1	0.3150	82	220
IE1-EG 200 L2-6	22	30	217	970	90	44.7	7	0.83	2.1	2.1	0.3600	82	250
IE1-EG 225 M-6	30	40	292	980	91.5	59.3	7	0.84	2	2.1	0.5470	82	292
IE1-EG 250 M-6	37	50	361	980	92	71	7	0.86	2.1	2.1	0.8340	84	408
IE1-EG 280 S-6	45	60	439	980	92.5	86	7	0.86	2.1	2	1.3900	85	536
IE1-EG 280 M-6	55	75	536	980	92.8	105	7	0.86	2.1	2	1.6500	85	595
IE1-EG 315 S-6	75	100	723	990	93.5	142	7	0.86	2	2	4.1100	90	990
IE1-EG 315 M-6	90	125	868	990	93.8	170	7	0.86	2	2	4.2800	90	1080
IE1-EG 315 L1-6	110	150	1061	990	94	207	6.7	0.86	2	2	5.4500	90	1150
IE1-EG 315 L2-6	132	180	1273	990	94.2	245	6.7	0.87	2	2	6.1200	89	1210
IE1-EG 355 M1-6	160	220	1543	990	94.5	292	6.7	0.88	1.9	2	8.8500	96	1600

• Reduced frame size.

* The electrical data are not restricted to the series, for more detailed information please ask. Data MSL Series and EGQ series.

ELECTRICAL DATA

Asynchronous three-phase motors, squirrel-case rotor.
External cooling IC 411, continuous service S1.
Isolating class 155(F), protection grade IP 55.

Aluminum motors **IE1-MS** series

Cast iron motors **IE1-EG** series

Synchronous speed 750 rpm - 8 poles

400 V, 50 Hz

TYPE	Power		M _N N.m	n rpm	IE1 efficiency class EN 60034-2-1 100%	I _N 400 V A	I _A /I _N	Cosφ	M _A /M _N	M _K /M _N	J Kgm ²	Noise level dB(A)	m Kg
	kW	CV											
MS 71 1-8	0.09	0.12	1.3	680	48	0.48	3	0.56	1.5	1.7	0.00084	50	5.6
MS 71 2-8	0.12	0.17	1.7	690	51	0.58	2.7	0.59	1.6	1.7	0.00087	50	6.0
MS 80 1-8	0.18	0.25	2.5	680	51	0.84	2.8	0.61	1.5	1.7	0.00140	52	9.4
MS 80 2-8	0.25	0.33	3.5	680	56	1.06	2.7	0.61	1.6	2	0.00186	52	10.1
• MS 80 3-8	0.37	0.5	5.2	680	63	1.35	2.8	0.63	1.6	1.8	0.00195	56	14.8
MS 90 S-8	0.37	0.5	5.2	680	63	1.35	2.8	0.63	1.6	1.8	0.00186	56	12.5
MS 90 L-8	0.55	0.75	7.7	680	66	1.85	3	0.65	1.6	1.8	0.00217	56	15.3
MS 100 L1-8	0.75	1	10.1	710	66	2.45	3.5	0.67	1.7	2.1	0.00563	59	17.2
MS 100 L2-8	1.1	1.5	14.8	710	72	3.2	3.5	0.69	1.7	2.1	0.00716	59	19.5
MS 112 M-8	1.5	2	20.2	710	74	4.3	4.2	0.68	1.8	2.1	0.01159	61	25.5
MS 132 S-8	2.2	3	29.2	720	75	5.96	5.5	0.71	2	2	0.02541	64	34.2
MS 132 M-8	3	4	39.8	720	77	7.7	5.5	0.73	2	2	0.03068	64	40.0
MS 160 M1-8	4	5.5	52.3	730	80	9.89	6	0.73	1.9	2.1	0.06927	68	59.0
MS 160 M2-8	5.5	7.5	73	720	83.5	12.9	6	0.74	2	2.2	0.09353	68	69.0
MS 160 L-8	7.5	10	99.5	720	85	17	6	0.75	1.9	2.2	0.11300	68	87.0
EG 160 M1-8	4	5.5	53.1	720	81	10.3	6	0.73	1.9	2	0.0753	76	118
EG 160 M2-8	5.5	7.5	73	720	83	13.6	6	0.74	2	2	0.0931	76	119
EG 160 L-8	7.5	10	99.5	720	85.5	17.8	6	0.75	2	2	0.1260	76	145
EG 180 L-8	11	15	143.9	730	87.5	25.1	6.6	0.76	2	2	0.2030	78	184
EG 200 L-8	15	20	196.2	730	88	34.1	6.6	0.76	2	2	0.3390	80	250
EG 225 S-8	18.5	25	242	730	90	41.1	6.6	0.76	1.9	2	0.4910	80	266
EG 225 M-8	22	30	283.9	740	90.5	47.4	6.6	0.78	1.9	2	0.5470	80	292
EG 250 M-8	30	40	387.2	740	91	63.4	6.6	0.79	1.9	2	0.8340	82	405
EG 280 S-8	37	50	477.5	740	91.5	78	6.6	0.79	1.9	2	1.3900	83	520
EG 280 M1-8	45	60	580.7	740	92	94	6.6	0.79	1.9	2	1.6500	82	592
EG 315 S-8	55	75	709.8	740	92.8	111	6.6	0.81	1.8	2	4.7900	88	1000
EG 315 M-8	75	100	967.9	740	93	151	6.6	0.81	1.8	2	5.5800	88	1100
EG 315 L1-8	90	125	1161.5	740	93.8	178	6.6	0.82	1.8	2	6.3700	88	1160
EG 315 L2-8	110	150	1419.6	740	94	217	6.4	0.82	1.8	2	7.2300	88	1230

• Reduced frame size.

* The electrical data are not restricted to the series, for more detailed information please ask. Data MSL Series and EGQ series.

ELECTRICAL DATA

Asynchronous single-phase motors with permanent condenser.
External cooling IC 411, continuous service S1.
F isolating class, IP 55 protection, 50 Hz.

Synchronous speed 3000 rpm - 2 poles

Aluminum motors **MY** series

TYPE	Power kW	CV	n rpm	I (Amp) 230 V	η %	Cos φ	M_A/M_N	M_S/M_N	I_A (A)	Permanent condensator (μ f/V)	Noise level dB(A)	m Kg
MY 56 1-2	0.09	0.12	2760	0.81	54	0.90	0.70	1.6	3	4 μ f/450V	67	2.9
MY 56 2-2	0.12	0.17	2770	0.98	58	0.92	0.70	1.6	4	6 μ f/450V	67	3.2
MY 63 1-2	0.18	0.25	2780	1.42	60	0.92	0.70	1.7	5	10 μ f/450V	70	4.0
MY 63 2-2	0.25	0.33	2780	1.94	61	0.92	0.68	1.7	7	12 μ f/450V	70	4.5
MY 71 1-2	0.37	0.5	2800	2.75	63	0.93	0.63	1.7	12	20 μ f/450V	75	5.1
MY 71 2-2	0.55	0.75	2810	3.50	72	0.95	0.63	1.7	15	25 μ f/450V	75	7.2
MY 80 1-2	0.75	1	2810	4.77	72	0.95	0.45	1.7	20	25 μ f/450V	75	9.6
MY 80 2-2	1.1	1.5	2810	6.80	74	0.95	0.43	1.7	28	35 μ f/450V	78	11.0
MY 90 S-2	1.5	2	2820	9.15	75	0.95	0.35	1.8	40	45 μ f/450V	80	14.0
MY 90 L-2	2.2	3	2820	13.08	77	0.95	0.35	1.8	60	60 μ f/450V	80	16.5
MY 100 L-2	3	4	2840	17.83	77	0.95	0.35	1.8	75	80 μ f/450V	83	25.0

Synchronous speed 1500 rpm - 4 poles

Aluminum motors **MY** series

TYPE	Power kW	CV	n rpm	I (Amp) 230 V	η %	Cos φ	M_A/M_N	M_S/M_N	I_A (A)	Permanent condensator (μ f/V)	Noise level dB(A)	m Kg
MY 56 1-4	0.06	0.09	1360	0.59	48	0.92	0.75	1.6	2.5	4 μ f/450V	63	3.5
MY 56 2-4	0.09	0.12	1370	0.83	51	0.92	0.75	1.6	3	6 μ f/450V	63	3.8
MY 63 1-4	0.12	0.17	1380	1.09	52	0.92	0.65	1.6	3.5	10 μ f/450V	65	4.0
MY 63 2-4	0.18	0.25	1380	1.55	55	0.92	0.65	1.5	5.5	12 μ f/450V	65	4.6
MY 71 1-4	0.25	0.33	1380	2.15	55	0.92	0.60	1.5	8	20 μ f/450V	65	5.7
MY 71 2-4	0.37	0.5	1380	2.91	60	0.92	0.55	1.5	10	20 μ f/450V	68	6.7
MY 80 1-4	0.55	0.75	1400	3.93	64	0.95	0.45	1.7	15	20 μ f/450V	70	9.5
MY 80 2-4	0.75	1	1410	5.05	68	0.95	0.45	1.7	20	25 μ f/450V	70	10.5
MY 90 S-4	1.1	1.5	1410	6.90	73	0.95	0.45	1.8	30	40 μ f/450V	73	14.5
MY 90 L-4	1.5	2	1420	9.38	74	0.94	0.45	1.8	40	45 μ f/450V	75	16.2
MY 100 L1-4	2.2	3	1430	13.75	74	0.94	0.30	1.8	60	80 μ f/450V	78	24.0
MY 100 L2-4	3	4	1440	17.83	77	0.95	0.45	1.7	76	100 μ f/450V	80	32.0

Synchronous speed 1000 rpm - 6 poles

Aluminum motors **MY** series

TYPE	Power kW	CV	n rpm	I (Amp) 230 V	η %	Cos φ	M_A/M_N	M_S/M_N	I_A (A)	Permanent condensator (μ f/V)	Noise level dB(A)	m Kg
MY 63 1-6	0.09	0.12	900	0.92	46	0.92	0.55	1.45	2	8 μ f/450V	63	5.1
MY 63 2-6	0.12	0.16	900	1.05	54	0.92	0.55	1.45	3	11 μ f/450V	63	6.0
MY 71 1-6	0.18	0.25	900	1.55	55	0.92	0.60	1.5	4	16 μ f/450V	68	6.3
MY 71 2-6	0.25	0.33	900	2.07	57	0.92	0.60	1.5	5	20 μ f/450V	68	7.6
MY 80 1-6	0.37	0.55	900	2.69	65	0.92	0.35	1.6	8	25 μ f/450V	68	9.0
MY 80 2-6	0.55	0.75	900	3.84	67	0.93	0.35	1.6	14	30 μ f/450V	70	11.6
MY 90 S-6	0.75	1	900	4.97	69	0.95	0.35	1.6	16	40 μ f/450V	70	13.5
MY 90 L-6	1.1	1.5	900	7.19	70	0.95	0.35	1.6	25	50 μ f/450V	70	16.2

* The electrical data are not restricted to the series, for more detailed information please ask. Data MY series.

ELECTRICAL DATA

Asynchronous three-phase motors, squirrel-case rotor.
External cooling IC 411, continuous service S1.
Isolating class 155(F), protection grade IP 55.

Aluminum motors **IE2-MS** series

Cast iron motors **IE2-EG** series

Synchronous speed 3000 rpm - 2 poles

400 V, 50 Hz

TYPE	Power		M _N N.m	n rpm	IE2 efficiency class EN 60034-2-1			I _N 400 V A	I _A /I _N	Cosφ	M _A /M _N	M _K /M _N	J Kgm ²	Noise level dB(A)	m Kg
	kW	CV			100%	75%	50%								
IE2-MS 80 1-2	0.75	1	2.5	2865	79.3	78.8	75.3	1.84	6.5	0.74	2.65	2.95	0.00092	67	9.8
IE2-MS 80 2-2	1.1	1.5	3.7	2865	81.1	80.7	77.2	2.55	6.2	0.77	2.5	2.6	0.00010	67	10.6
IE2-MS 90 S-2	1.5	2	5	2875	81.4	80.9	78	3.2	6.5	0.83	2.5	2.9	0.00160	72	13.9
IE2-MS 90 L-2	2.2	3	7.3	2885	83.3	82.4	79	4.8	7.2	0.80	2.9	3	0.00193	72	16.7
IE2-MS 100 L-2	3	4	9.9	2900	84.7	84.2	83.2	5.9	8.5	0.87	2.9	2.5	0.00554	76	24.8
IE2-MS 112 M-2	4	5.5	13.1	2910	86	85.2	84.5	7.69	8.4	0.87	2.6	3.3	0.00586	77	30.0
IE2-MS 132 S1-2	5.5	7.5	17.8	2950	87.7	86.4	82.2	10.88	9.8	0.83	4	5	0.01438	80	45.4
IE2-MS 132 S2-2	7.5	10	24.4	2935	89.7	89.1	86.9	13.6	10.5	0.89	3	3.8	0.01670	80	53.8
IE2-EG 160 M1-2	11	15	35.9	2930	89.4	89.3	87.8	19.9	8.1	0.89	2.2	2.3	0.0489	81	123
IE2-EG 160 M2-2	15	20	48.9	2930	90.3	90.2	88.8	26.9	8.1	0.89	2.2	2.3	0.0559	81	132
IE2-EG 160 L-2	18.5	25	60.3	2930	90.9	90.8	89.5	33	8.1	0.89	2.2	2.3	0.0648	81	151
IE2-EG 180 M-2	22	30	71.5	2940	91.3	91.2	89.9	38.6	8.1	0.88	2	2.3	0.0808	83	203
IE2-EG 200 L1-2	30	40	97.1	2950	92	91.9	90.7	52.3	8.1	0.88	2	2.3	0.1630	84	246
IE2-EG 200 L2-2	37	50	120	2950	92.5	92.4	91.3	64.1	8.1	0.89	2	2.3	0.1720	84	256
IE2-EG 225 M-2	45	60	145	2960	92.9	92.8	91.8	77.7	8.1	0.89	2	2.3	0.3020	86	328
IE2-EG 250 M-2	55	75	177	2965	93.2	93.1	92.1	94.6	8.1	0.90	2	2.3	0.4200	89	433
IE2-EG 280 S-2	75	100	242	2960	93.8	93.7	92.8	128	8.1	0.90	2	2.3	0.9860	91	572
IE2-EG 280 M-2	90	125	290	2960	94.1	94	93.1	151	8.1	0.91	2	2.3	1.0400	91	632
IE2-EG 315 S-2	110	150	353	2975	94.3	94.2	93.4	185	7.7	0.90	1.8	2.2	1.3300	92	950
IE2-EG 315 M-2	132	180	424	2975	94.6	94.5	93.7	221	7.7	0.90	1.8	2.2	1.5000	92	1080
IE2-EG 315 L1-2	160	220	514	2975	94.8	94.8	93.9	264	7.7	0.89	1.8	2.2	1.6700	92	1210
IE2-EG 315 L2-2	200	270	642	2975	95	95	94.2	330	7.7	0.89	1.8	2.2	1.8800	92	1240
IE2-EG 355 M-2	250	340	801	2980	95	95	94.2	412	7.7	0.92	1.6	2.2	4.0200	100	1970
IE2-EG 355 L1-2	315	430	1009	2980	95	95	94.2	520	7.7	0.92	1.6	2.2	4.8600	100	2000

* The electrical data are not restricted to the series, for more detailed information please ask. Data of MSX and EGQ series.

ELECTRICAL DATA

Asynchronous three-phase motors, squirrel-case rotor.
External cooling IC 411, continuous service S1.
Isolating class 155(F), protection grade IP 55.

Aluminum motors **IE2-MS** series

Cast iron motors **IE2-EG** series

Synchronous speed 1500 rpm - 4 poles

400 V, 50 Hz

TYPE	Power		M _N N.m	n rpm	IE2 efficiency class EN 60034-2-1			I _N 400 V A	I _A /I _N	Cosφ	M _A /M _N	M _K /M _N	J Kgm ²	Noise level dB(A)	m Kg
	kW	CV			100%	75%	50%								
IE2-MS 80 2-4	0.75	1	5.02	1420	79.5	79.7	77.5	1.88	5.7	0.73	2.85	2.77	0.0027	58	12.0
IE2-MS 90 S-4	1.1	1.5	7.35	1430	81.5	81.6	79.3	2.67	6	0.73	2.8	2.35	0.0031	61	14.0
IE2-MS 90 L-4	1.5	2	10	1430	82.9	83	80.2	3.57	6.3	0.73	2.9	2.3	0.0040	61	17.8
IE2-MS 100 L1-4	2.2	3	14.5	1450	84.5	84.7	82.2	4.85	6.2	0.78	2.2	2.6	0.0076	64	23.5
IE2-MS 100 L2-4	3	4	19.8	1450	85.5	85.7	83.8	6.49	6.6	0.78	2.5	2.6	0.0092	64	27.4
IE2-MS 112 M-4	4	5.5	26.3	1455	86.7	85.9	82.1	8.58	7.3	0.78	2.5	2.9	0.0123	65	35.7
IE2-MS 132 S-4	5.5	7.5	36.1	1455	88	86.8	84.4	11	7.3	0.82	2.3	2.8	0.0204	72	45.4
IE2-MS 132 M-4	7.5	10	49.3	1455	88.8	89.2	88.2	14.25	7	0.86	2.2	2.4	0.0296	72	58.6
IE2-EG 160 M-4	11	15	72	1460	89.8	89.7	88.2	21	8.9	0.84	2.2	2.3	0.0771	73	123
IE2-EG 160 L-4	15	20	98.1	1460	90.6	90.5	89.1	28.1	8.9	0.85	2.2	2.3	0.1010	73	153
IE2-EG 180 M-4	18.5	25	120	1470	91.2	91.1	89.8	34	7.9	0.86	2.2	2.3	0.1520	76	204
IE2-EG 180 L-4	22	30	143	1470	91.6	91.5	90.3	40.3	7.9	0.86	2.2	2.3	0.1870	76	215
IE2-EG 200 L-4	30	40	195	1470	92.3	92.2	91.1	54.5	7.9	0.86	2.2	2.3	0.2850	76	243
IE2-EG 225 S-4	37	50	240	1475	92.7	92.6	91.5	66.2	7.9	0.87	2.2	2.3	0.4730	78	305
IE2-EG 225 M-4	45	60	292	1470	93.1	93	92	80.1	7.9	0.87	2.2	2.3	0.5540	78	328
IE2-EG 250 M-4	55	75	355	1480	93.5	93.4	92.4	97.5	7.9	0.87	2.2	2.3	0.7510	79	452
IE2-EG 280 S-4	75	100	486	1475	94	93.9	93	132	7.9	0.87	2.2	2.3	1.9200	80	592
IE2-EG 280 M-4	90	125	583	1475	94.2	94.1	93.3	158	7.9	0.87	2.2	2.3	2.3200	80	672
IE2-EG 315 S-4	110	150	707	1485	94.5	94.4	93.6	195	7.6	0.86	2.1	2.2	2.3400	88	980
IE2-EG 315 M-4	132	180	849	1485	94.7	94.6	93.8	233	7.6	0.86	2.1	2.2	2.5800	88	1040
IE2-EG 315 L1-4	160	220	1029	1485	94.9	94.9	94.1	282	7.6	0.86	2.1	2.2	2.9600	88	1180
IE2-EG 315 L2-4	200	270	1286	1485	95.1	95.1	94.3	357	7.6	0.85	2.1	2.2	3.4600	88	1260
IE2-EG 355 M-4	250	340	1608	1485	95.1	95.1	94.3	421	7.6	0.90	2.1	2.2	6.6000	95	1810
IE2-EG 355 L2-4	315	430	2026	1485	95.1	95.1	94.3	537	7.6	0.89	2.1	2.2	7.5500	95	1910

* The electrical data are not restricted to the series, for more detailed information please ask. Data of MSX and EGQ series.

ELECTRICAL DATA

Asynchronous three-phase motors, squirrel-case rotor.
External cooling IC 411, continuous service S1.
Isolating class 155(F), protection grade IP 55.

Aluminum motors **IE2-MS** series

Cast iron motors **IE2-EG** series

Synchronous speed 1000 rpm - 6 poles

400 V, 50 Hz

TYPE	Power		M _N N.m	n rpm	IE2 efficiency class EN 60034-2-1 400 V			I _N A	I _A /I _N	Cosφ	M _A /M _N	M _K /M _N	J Kgm ²	Noise level dB(A)	m Kg
	kW	CV			100%	75%	50%								
IE2-MS 90 S-6	0.75	1	7.74	925	75.9	75.2	71.6	1.92	4.5	0.75	2.2	2.5	0.0038	59	14.0
IE2-MS 90 L-6	1.1	1.5	11.3	930	78.2	77.7	74.2	2.71	4.8	0.75	2.4	2.6	0.0050	60	18.0
IE2-MS 100 L-6	1.5	2	15.24	940	79.9	78.8	74.6	3.69	6.2	0.74	3.3	3	0.0095	61	23.2
IE2-MS 112 M-6	2.2	3	22.23	945	81.8	81.6	78.6	5	6.1	0.78	2.8	2.6	0.0177	64	29.2
IE2-MS 132 S-6	3	4	29.84	960	83.4	83.2	80.4	6.7	6.4	0.78	2.5	2.5	0.0312	66	37.8
IE2-MS 132 M1-6	4	5.5	39.79	960	85.6	85	82.2	8.7	7.5	0.78	2.9	2.7	0.0460	68	42.7
IE2-MS 132 M2-6	5.5	7.5	54.7	960	86.5	86	83.3	11.7	7.7	0.79	2.9	2.6	0.0572	69	52.5
IE2-EG 160 M-6	7.5	10	73.8	970	87.2	87.1	85.3	16.1	6	0.77	2	2.1	0.0964	73	151
IE2-EG 160 L-6	11	15	108	970	88.7	88.6	87	22.9	6	0.78	2	2.1	0.1270	73	167
IE2-EG 180 L-6	15	20	148	970	89.7	89.6	88.1	29.7	7.5	0.81	2	2.1	0.2010	73	206
IE2-EG 200 L1-6	18.5	25	182	970	90.4	90.3	88.9	36.4	7.5	0.81	2.1	2.1	0.3250	73	243
IE2-EG 200 L2-6	22	30	217	970	90.9	90.8	89.5	42	7.5	0.83	2.1	2.1	0.3710	73	256
IE2-EG 225 M-6	30	40	292	980	91.7	91.6	90.4	56.2	7.5	0.84	2	2.1	0.5330	74	317
IE2-EG 250 M-6	37	50	361	980	92.2	92.1	91	67.3	7.5	0.86	2.1	2.1	0.8770	76	435
IE2-EG 280 S-6	45	60	439	980	92.7	92.6	91.5	81.4	7.5	0.86	2.1	2	1.8500	78	603
IE2-EG 280 M-6	55	75	536	980	93.1	93	92	99.1	7.5	0.86	2.1	2	2.1200	78	693
IE2-EG 315 S-6	75	100	727	985	93.7	93.6	92.7	135	7.5	0.85	2	2	2.6100	83	970
IE2-EG 315 M-6	90	125	873	985	94	93.9	93	162	7.5	0.85	2	2	3.0400	83	1180
IE2-EG 315 L1-6	110	150	1066	985	94.3	94.2	93.4	195	7.3	0.86	2	2	3.7100	83	1240
IE2-EG 315 L2-6	132	180	1280	985	94.6	94.5	93.7	234	7.3	0.86	2	2	4.2400	83	1300
IE2-EG 355 M1-6	160	220	1543	990	94.8	94.8	93.9	276	7.3	0.88	1.9	2	7.4400	85	1740

* The electrical data are not restricted to the series, for more detailed information please ask. Data of MSX and EGQ series.

DIMENSIONS

Aluminum motors **IE1-MS** series

Construction Types **B3 - B5 - B5R - B14 - B14G**

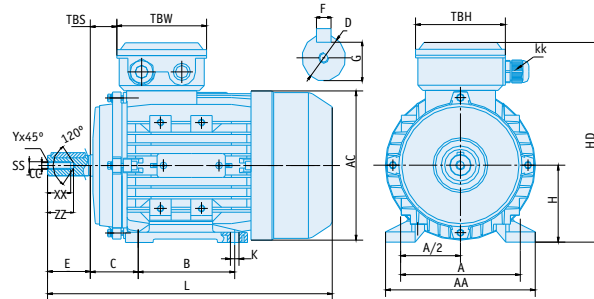

IM B3 / IM 1001											Shaft Tolerances J6									
Frame	A	AA	AC	B	C	H	HD	K	KK	L	TBS	TBW	TBH	D	E	F	G	SS	XX	ZZ
56	90	110	117	71	36	56	156	5.8x8.8	1-M16x1.5	196	14	88	88	9	20	3	7.2	M3	9	12
63	100	120	130	80	40	63	171	7x10	1-M16x1.5	220	14	94	94	11	23	4	8.5	M4	10	14
71*	112	132	147	90	45	71	186	7x10	1-M20x1.5	241 (255)	20	94	94	14	30	5	11.0	M5	12	17
80	125	160	163	100	50	80	213	10x13	1-M20x1.5	290	27	105	105	19	40	6	15.5	M6	16	21
90S	140	175	183	100	56	90	229	10x13	1-M20x1.5	312	30	105	105	24	50	8	20	M8	19	25
90L1	140	175	183	125	56	90	229	10x13	1-M20x1.5	337	30	105	105	24	50	8	20	M8	19	25
90L2	140	175	183	125	56	90	229	10x13	1-M20x1.5	367	30	105	105	24	50	8	20	M8	19	25
100*	160	198	205	140	63	100	252	12x15	2-M20x1.5	369 (387)	26	105	105	28	60	8	24	M10	22	30
112	190	220	229	140	70	112	279	12x15	2-M25x1.5	395	32	112	112	28	60	8	24	M10	22	30
132S	216	252	265	140	89	132	318	12x15	2-M25x1.5	437	38	112	112	38	80	10	33	M12	28	37
132M	216	252	265	178	89	132	318	12x15	2-M25x1.5	475	38	112	112	38	80	10	33	M12	28	37
132L	216	252	265	178	89	132	318	12x15	2-M25x1.5	501	38	112	112	38	80	10	33	M12	28	37
160M	254	290	325	210	108	160	384	15x19	2-M32x1.5	640	64	143	143	42	110	12	37	M16	36	45
160L	254	290	325	254	108	160	384	15x19	2-M32x1.5	640	64	143	143	42	110	12	37	M16	36	45

* IEC Frame (reduced frame size).

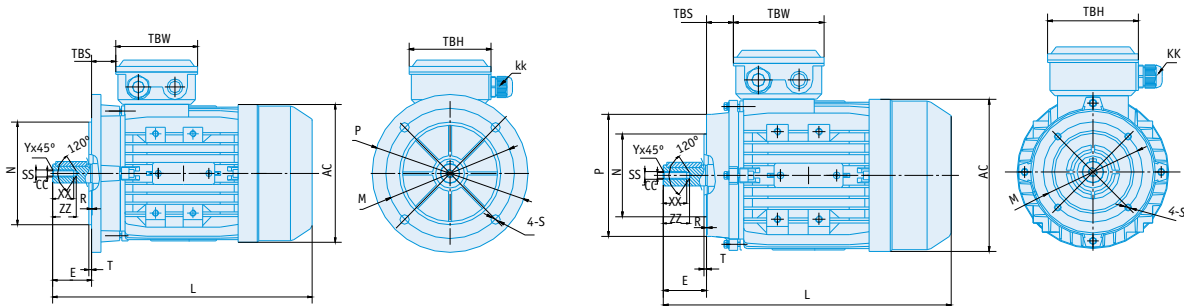

Frame	IM B5 / IM 3001 4 Holes at 45°					IM B5R 4 Holes at 45°					IM B14 / IM 3601 4 Holes at 45°					IM B14G / IM 3601 G 4 Holes at 45°				
	M	N	P	S	T	M	N	P	S	T	M	N	P	S	T	M	N	P	S	T
56	100	80	120	7	3.0	NOT AVAILABLE					65	50	80	M5	2.5	NOT AVAILABLE				
63	115	95	140	10	3.0	NOT AVAILABLE					75	60	90	M5	2.5	100	80	120	M6	2.5
71	130	110	160	10	3.5	115	95	140	10	3.0	85	70	105	M6	2.5	115	95	140	M8	3.0
80	165	130	200	12	3.5	130	110	160	10	3.5	100	80	120	M6	3.0	130	110	160	M8	3.5
90	165	130	200	12	3.5	130	110	160	10	3.5	115	95	140	M8	3.0	130	110	160	M8	3.5
100	215	180	250	15	4.0	165	130	200	12	3.5	130	110	160	M8	3.5	165	130	200	M10	3.5
112	215	180	250	15	4.0	165	130	200	12	3.5	130	110	160	M8	3.5	165	130	200	M10	3.5
132	265	230	300	15	4.0	215	180	250	15	4.0	165	130	200	M10	4.0	215	180	250	M12	4.0
160	300	250	350	19	5.0	NOT AVAILABLE					215	180	250	M12	4.0	NOT AVAILABLE				

*The dimensions are not restricted to the series, for more information please ask. Dimensions MSL series.

DIMENSIONS

Aluminum motors **IE2-MS** series

Construction Types **B3 - B5 - B5R - B14 - B14G**

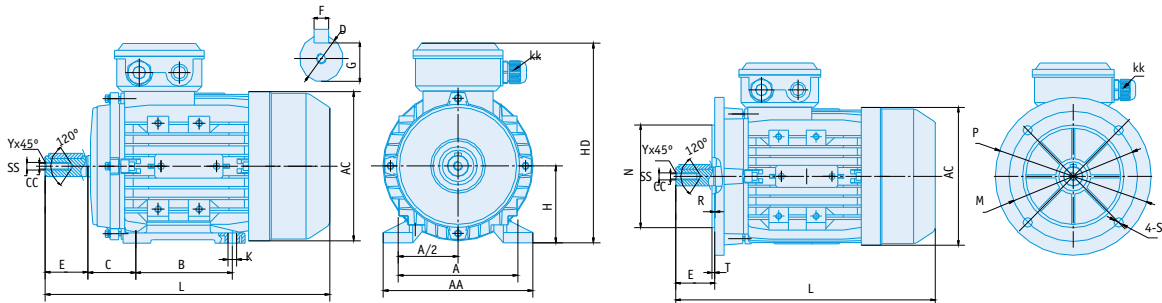

IM B3 / IM 1001											Shaft Tolerances J6					IM B5 / IM 3001 4 Holes at 45°				
Frame	A	AA	AC	B	C	H	HD	K	KK	L	D	SS	E	F	G	M	N	P	S	T
80	125	155	158	100	50	80	210	10	1-M20x1.5	295	19	M6	40	6	15.5	165	130	200	12	3.5
90S	140	180	179	100	56	90	228	10	1-M20x1.5	320	24	M8	50	8	20	165	130	200	12	3.5
90L	140	180	179	125	56	90	228	10	1-M20x1.5	345	24	M8	50	8	20	165	130	200	12	3.5
100	160	200	202	140	63	100	260	12	1-M20x1.5	385	28	M10	60	8	24	215	180	250	15	4.0
112	190	233	225	140	70	112	285	12	2-M25x1.5	410	28	M10	60	8	24	215	180	250	15	4.0
132S	216	255	260	140	89	132	325	12	2-M25x1.5	470	38	M12	80	10	33	265	230	300	15	4.0
132M	216	255	260	178	89	132	325	12	2-M25x1.5	510	38	M12	80	10	33	265	230	300	15	4.0

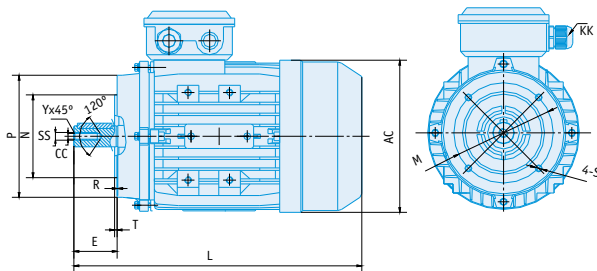

IM B5R 4 Holes at 45°					
Frame	M	N	P	S	T
80	130	110	160	12	3.5
90	130	110	160	12	3.5
100	165	130	200	15	3.5
112	165	130	200	15	3.5
132	215	180	250	15	4.0

IM B14 / IM 3601 4 Holes at 45°					
Frame	M	N	P	S	T
80	100	80	120	M6	3.0
90	115	95	140	M8	3.0
100	130	110	160	M8	3.5
112	130	110	160	M8	3.5
132	165	130	200	M10	4.0

IM B14G / IM 3601 G 4 Holes at 45°					
Frame	M	N	P	S	T
80	130	110	160	M8	3.5
90	130	110	160	M8	3.5
100	165	130	200	M10	3.5
112	165	130	200	M10	3.5
132	215	180	250	M12	4.0

*The dimensions are not restricted to the series, for more info please ask. Dimensions MSX series.

DIMENSIONS

Cast iron **IE1-IE2 EG** series
Construction Types **B3 - B5**

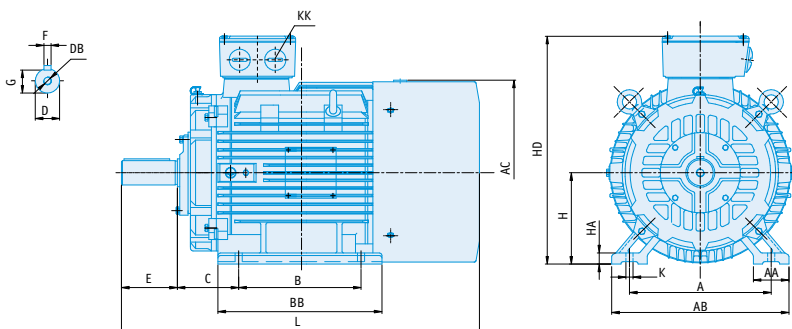

IM B3 / IM 1001															Shaft tolerances				
Frame	Poles	A	AA	AB	AC	B	BB	C	H	HA	HD	K	KK	L	D	DB	E	F	G
160M	2-8	254	73	320	330	210	318	108	160	20	420	15	2-M40x1.5	659	42	M16x36	110	12	37
160L	2-8	254	73	320	330	254	362	108	160	20	420	15	2-M40x1.5	714	42	M16x36	110	12	37
180M	2-8	279	73	355	380	241	349	121	180	22	455	15	2-M40x1.5	738	48	M16x36	110	14	42.5
180L	2-8	279	73	355	380	279	387	121	180	22	455	15	2-M40x1.5	778	48	M16x36	110	14	42.5
200L	2-8	318	73	395	400	305	375	133	200	25	505	19	2-M50x1.5	770	55	M20x42	110	16	49
225S	4-8	356	83	435	470	286	375	149	225	28	560	19	2-M50x1.5	820	60	M20x42	140	18	53
225M	2	356	83	435	470	311	400	149	225	28	560	19	2-M50x1.5	815	55	M20x42	110	16	49
225M	4-8	356	83	435	470	311	400	149	225	28	560	19	2-M50x1.5	845	60	M20x42	140	18	53
250M	2	406	88	490	510	349	450	168	250	30	615	24	2-M63x1.5	910	60	M20x42	140	18	53
250M	4-8	406	88	490	510	349	450	168	250	30	615	24	2-M63x1.5	910	65	M20x42	140	18	58
280S	2	457	93	550	547	368	490	190	280	35	680	24	2-M63x1.5	985	65	M20x42	140	18	58
280S	4-8	457	93	550	547	368	490	190	280	35	680	24	2-M63x1.5	985	75	M20x42	140	20	67.5
280M	2	457	93	550	547	419	540	190	280	35	680	24	2-M63x1.5	1035	65	M20x42	140	18	58
280M	4-8	457	93	550	547	419	540	190	280	35	680	24	2-M63x1.5	1035	75	M20x42	140	20	67.5
315S	2	508	120	635	645	406	575	216	315	45	845	28	2-M63x1.5	1185	65	M20x42	140	18	58
315S	4-8	508	120	635	645	406	575	216	315	45	845	28	2-M63x1.5	1215	80	M20x42	170	22	71
315M	2	508	120	635	645	457	685	216	315	45	845	28	2-M63x1.5	1295	65	M20x42	140	18	58
315M	4-8	508	120	635	645	457	685	216	315	45	845	28	2-M63x1.5	1325	80	M20x42	170	22	71
315L	2	508	120	635	645	508	685	216	315	45	845	28	2-M63x1.5	1295	65	M20x42	140	18	58
315L	4-8	508	120	635	645	508	685	216	315	45	845	28	2-M63x1.5	1325	80	M20x42	170	22	71
355M	2	610	120	730	710	560	750	254	355	52	1010	28	2-M63x1.5	1500	75	M24x50	140	20	67.5
355M	4-8	610	120	730	710	560	750	254	355	52	1010	28	2-M63x1.5	1530	100	M24x50	210	28	90
355L	2	610	120	730	710	630	750	254	355	52	1010	28	2-M63x1.5	1500	75	M24x50	140	20	67.5
355L	4-8	610	120	730	710	630	750	254	355	52	1010	28	2-M63x1.5	1530	100	M24x50	210	28	90

Shaft tolerances. Diameter up to 48 are k6. Rest are m6.

IM B5 / IM 3001						
Frame	P	N	M	S	T	LA
160	350	250	300	19	5	15
180	350	250	300	19	5	18
200	400	300	350	19	5	18
225	450	350	400	19	5	20
250	550	450	500	19	5	22
280	550	450	500	19	5	22
315	660	550	600	24	6	24
355	800	680	740	24	6	24

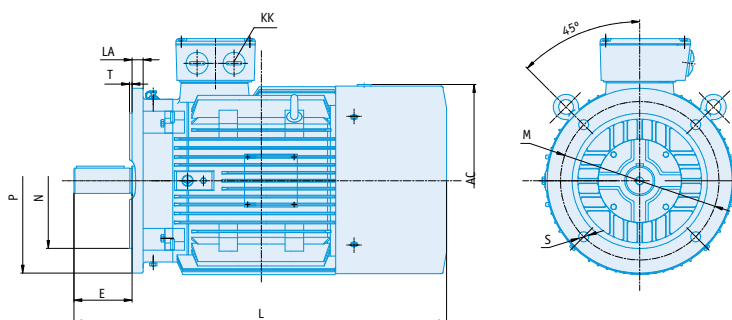

Frame 160, 180 and 200, 4 holes at 45°. Rest 8 holes at 22.5°.

* The dimensions are not restricted to the series, for more info please ask. Dimensions EGQ series.

DIMENSIONS

Aluminum motors **MY** series

Construction Types B3 - B5 - B5R - B14 - B14G

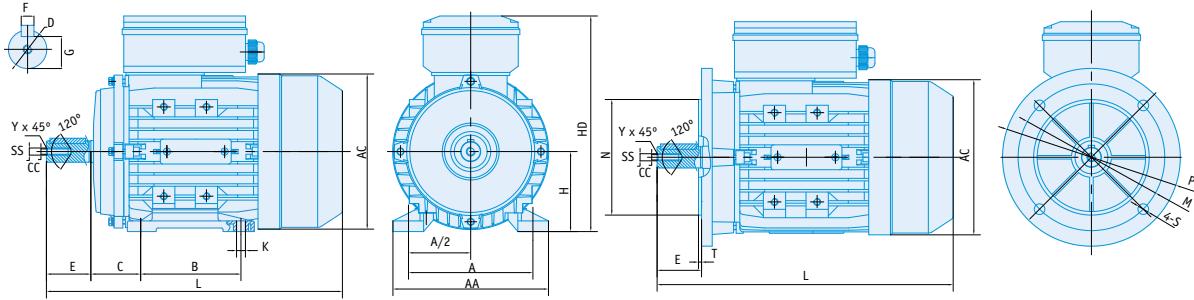

IM B3 / IM 1001										Shaft Tolerances k6					IM B5 / IM 3001 4 Holes at 45°				
Frame	A	AA	AC	B	C	H	HD	K	L	D	SS	E	F	G	M	N	P	S	T
56	90	110	117	71	36	56	144	5.8x8.8	196	9	M3	20	3	7.2	100	80	120	7	3.0
63	100	120	130	80	40	63	181	7x10	220	11	M4	23	4	8.5	115	95	140	10	3.0
71	112	132	147	90	45	71	196	7x10	255	14	M5	30	5	11	130	110	160	10	3.5
80	125	160	163	100	50	80	226	10x13	290	19	M6	40	6	15.5	165	130	200	12	3.5
90S	140	175	183	100	56	90	243	10x13	312	24	M8	50	8	20	165	130	200	12	3.5
90L	140	175	183	125	56	90	243	10x13	367	24	M8	50	8	20	165	130	200	12	3.5
100	160	198	205	140	63	100	265	12x15	387	28	M10	60	8	24	215	180	250	15	4.0

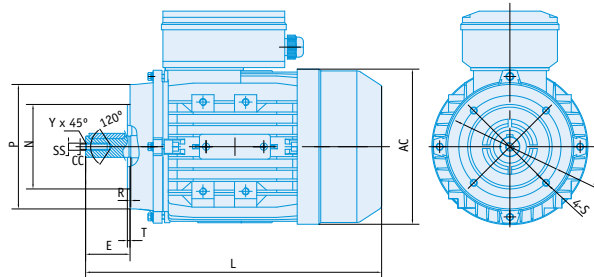

IM B5R 4 Holes at 45°					
Frame	M	N	P	S	T
56	NOT AVAILABLE				
63	NOT AVAILABLE				
71	115	95	140	10	3.0
80	130	110	160	12	3.5
90	130	110	160	12	3.5
100	165	130	200	15	3.5

IM B14 / IM 3601 4 Holes at 45°					
Frame	M	N	P	S	T
56	65	50	80	M5	2.5
63	75	60	90	M5	2.5
71	85	70	105	M6	2.5
80	100	80	120	M6	3.0
90	115	95	140	M8	3.0
100	130	110	160	M8	3.5

IM B14G / IM 3601 G 4 Holes at 45°					
Frame	M	N	P	S	T
56	NOT AVAILABLE				
63	100	80	120	M6	2.5
71	115	95	140	M8	3.0
80	130	110	160	M8	3.5
90	130	110	160	M8	3.5
100	165	130	200	M10	3.5

* The dimensions are not restricted to the series, for more info please ask. Dimensions MY series.

SPARE PARTS



Aluminum motors

SPARE PARTS

Aluminum motor **MS** series, frame size 56-160.

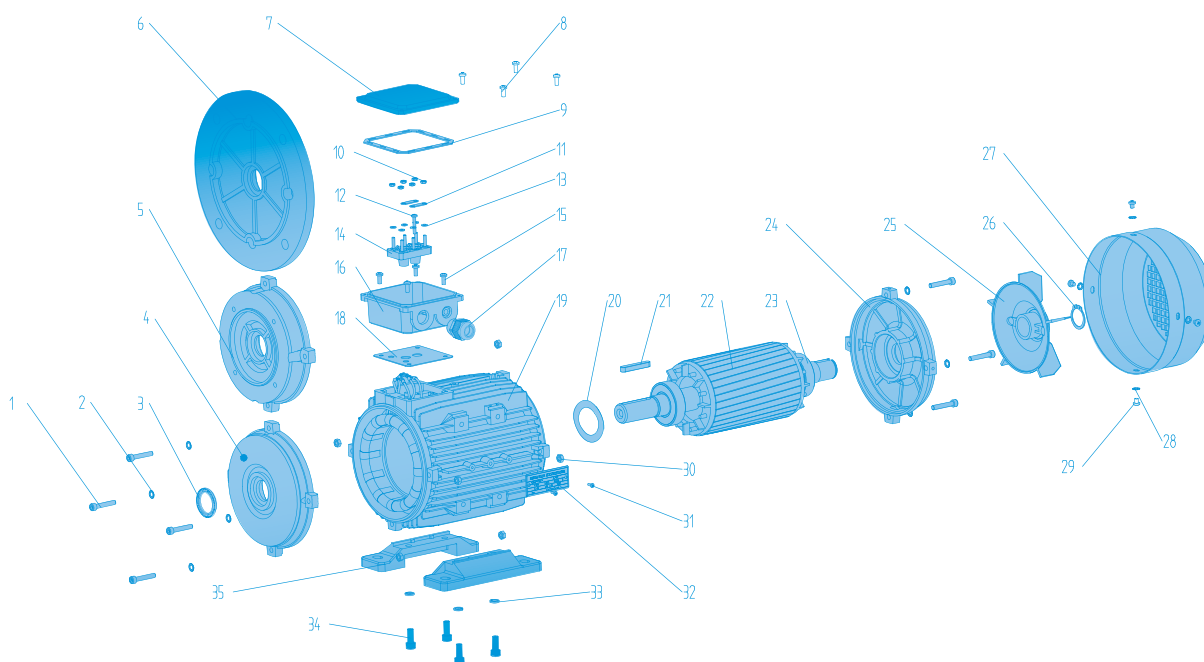

- | | |
|----------------------------|--------------------|
| 1 Front shield screw | 19 Frame |
| 2 Grover washer | 20 Wavy washer |
| 3 Retainer | 21 Key |
| 4 Front shield | 22 Rotor + shaft |
| 5 Flange B14 | 23 Bearing |
| 6 Flange B5 | 24 End shield |
| 7 Terminal box cover | 25 Fan |
| 8 Terminal box cover screw | 26 Circlip |
| 9 Terminal box cap joint | 27 Fan cover |
| 10 Terminal box nut | 28 Grover washer |
| 11 Bridges | 29 Fan cover screw |
| 12 Terminal box screw | 30 End shield nut |
| 13 Flat washer | 31 Rivet |
| 14 Terminal plate | 32 Nameplate |
| 15 Screw terminal plate | 33 Grover washer |
| 16 Terminal box plate | 34 Screw feet |
| 17 Cable gland | 35 Feet |
| 18 Terminal box base joint | |

* The spare parts are not restricted to the series, for more information please ask. Parts series MS.

SPARE PARTS



Cast iron motors

SPARE PARTS

Cast iron motors **EG** series, frame size 160-355.

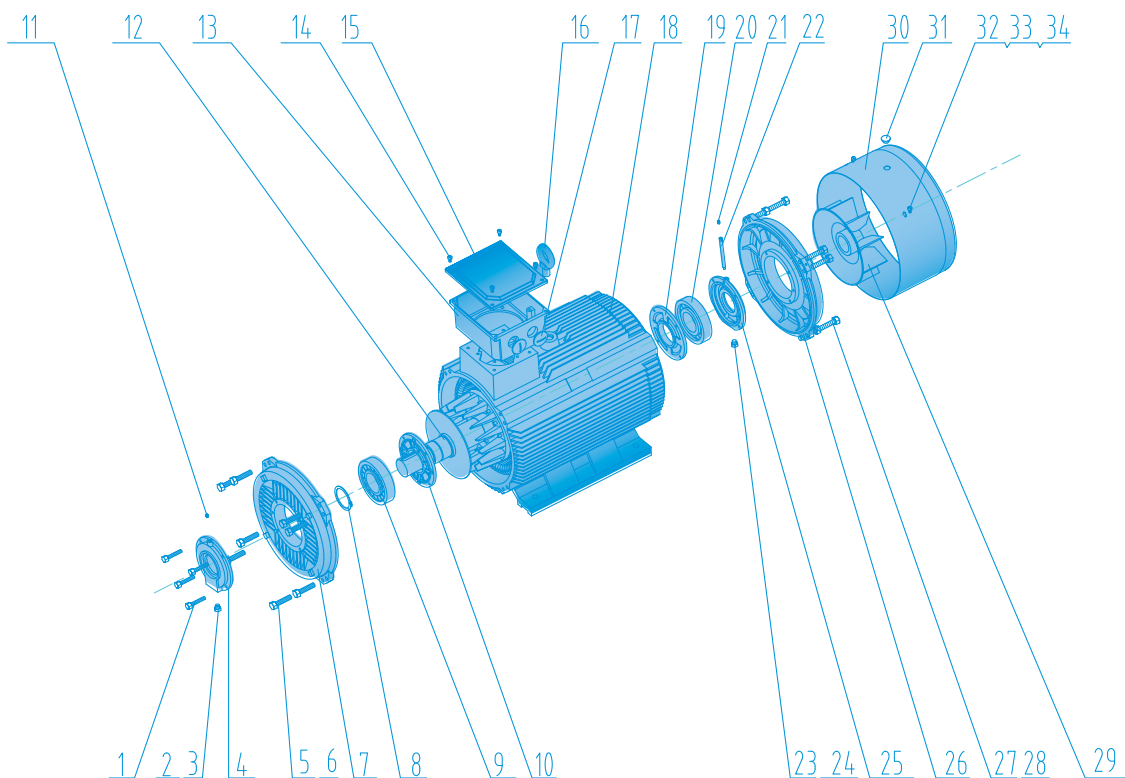

- | | |
|--|--|
| 1 Bearing housing screw (shaft side) | 18 Frame |
| 2 Greaser cap | 19 Internal bearing housing (fan side) |
| 3 Washer | 20 Bearing fan side |
| 4 Bearing housing (shaft side) | 21 Greaser |
| 5 Shield screw (shaft side) | 22 Pipe greaser |
| 6 Grower washer | 23 Cap greaser |
| 7 Shield (shaft side) | 24 Washer |
| 8 Circlip | 25 Bearing housing (fan side) |
| 9 Bearing front side | 26 Shield fan side |
| 10 Internal bearing housing (shaft side) | 27 Shield screw (fan side) |
| 11 Greaser | 28 Grower washer |
| 12 Rotor + shaft | 29 Fan |
| 13 Terminal box base | 30 Fan cover |
| 14 Terminal box cap screw | 31 Cap |
| 15 Terminal box cap | 32 Fan cover screw |
| 16 Eyebolt | 33 Flat washer |
| 17 Cable Gland | 34 Grower washer |

* The spare parts are not restricted to the series, for more information please ask. Parts series EG.

WARRANTIES, RETURNS AND COMPLAINTS



WARRANTIES

- **COSGRA** guarantees the supplied motors against faulty materials or manufacture for a period of one year from the date of shipment, taking as the valid date that indicated on the deliver note. Except with specific agreement made at the time of the offer or the acceptance of the order.
- All repairs will be carried out in the **COSGRA** workshops. Costs relating to the disassembly, packing, transport, customs, taxes etc. incurred in the shipment of the product to the **COSGRA** workshop and its subsequent delivery are not covered by the warranty.
- **COSGRA** can agree with the purchaser to carry out repairs or replacement of the defective parts in the purchaser's workshops. **COSGRA** will not accept responsibility for repairs carried out by third parties.
- The warranty consists of the repair or replacement of defective parts, caused by defective materials or manufacturing faults. If applicable, we will replace the complete defective motor for a new one and assume the shipment costs of the return and re-shipping.
- The repair or replacement of a defective part does not change the initial of date warranty period of the supplied goods. However, the replaced or repaired parts will be guaranteed for one year from the date of repair or replacement.
- Excluded from the warranty application: damages caused by normal wear and tear, damage or defects caused by an incorrect installation, inadequate care or maintenance, incorrect storage or handling, modifications made without written authorization from **COSGRA**, and all general causes non-attributable to **COSGRA**.
- For reasons explained above, **COSGRA** is not responsible for defects in motors or goods supplied after a period exceeding one year from the delivery date.
- **COSGRA** will not be responsible, in any case, for indirect and/or consequential damage that might occur as a result of the goods supplied; loss of production, breakdowns or cost of stops, etc.
- The total contractual liability of **COSGRA** for the goods supplied is limited to the value of the goods that have given rise to the claim. Such limitation shall not apply to liability for direct damage to people and property.
- It is exclusive responsibility and care of the buyer or end-user for the proper functioning, or care, or maintenance of the goods supplied.

REFUNDS. COMPLAINTS.

- **COSGRA** will not accept goods for refund without previous agreement with the Purchaser. We stipulate a 15 day period after the goods are received by the Purchaser, for notifying **COSGRA** of the intention to return the goods, to provide the related justification, and agree with **COSGRA** the refund procedure. In all cases the Purchaser's complaint to **COSGRA** must be in writing and in a certifiable manner.
- The costs of returns or goods shipments to **COSGRA** facilities, either for refund, replacement or repair, must always be met by the Purchaser.
- **COSGRA** will not accept the return of goods that have been used, mounted in other equipment or installations, or that have been disassembled by parties other than **COSGRA**.
- **COSGRA** will not accept the return of goods, which have been designed or manufactured specially to order.

REPARK
WWW.REPARK.LV





ELECTRIC MOTORS, AC

Single Phase | Three Phase | Self-braking | Anti-explosion pump | Flameproof | Variable speed

MECHANICAL SEALS FOR ROTARY SHAFTS

Tel. 28307515 e-pasts: info@repark.lv www.repark.lv

