

rev 1.1

DATA SHEET
HG HYDRAULIC GENERATOR



HG40C-U415SS23-108-K

DIMENSIONS

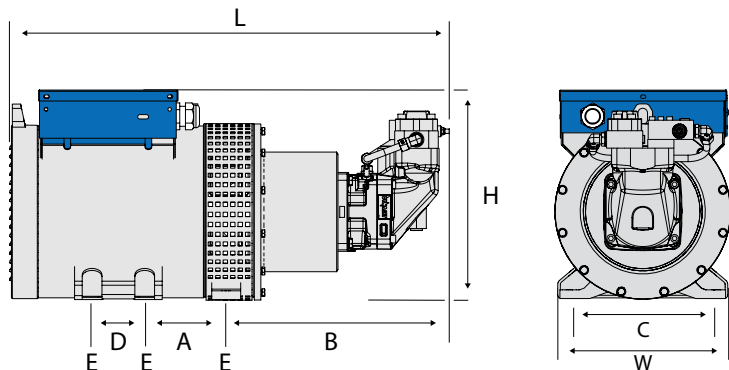

MODEL	DIMENSIONS, mm (in)								WEIGHT
	L	W	H	A	B	C	D	E	kg (lbs)
HG40C-U415SS23-108-K	989 (38.95)	384 (15.7)	478 (18.85)	184 (7.2)	503 (19.8)	340 (13.4)	120 (4.7)	Ø16,5 (0.6)	198 (437)

HYDRAULIC PORTS

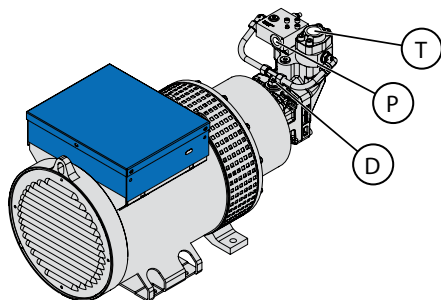

MODEL	PRESSURE LINE	RETURN LINE	DRAIN LINE
HG40C-U415SS23-108-K	P BSP 3/4"	T BSP 3/4"	D M22x1,5

CABLE WIRING

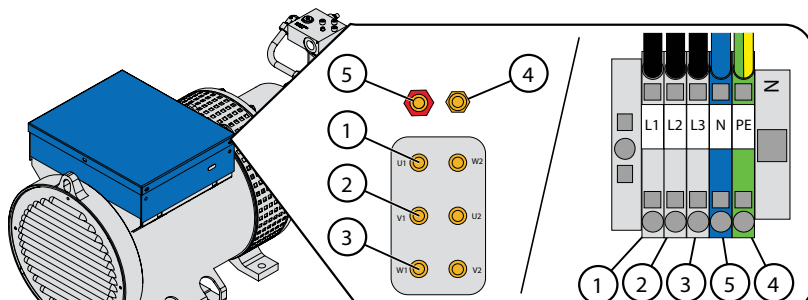

MODEL	ELECTRIC CONNECTIONS				
HG40C-U415SS23-108-K	1 L1	2 L2	3 L3	4 Ground	5 N

TECHNICAL SPECIFICATIONS

		HG40C-U415SS23-108-K
OUTPUT CHARACTERISTICS		
Output Power max.	kVA	40
Output Voltage*	V	120/208
Nominal Current 1~phase** / 3~phase	A	166,5 / 111,0
Frequency	Hz	60
Power factor	cos φ	0,8
Frequency control		FLC2
Phase		1 / 3
IP		IP23
Voltage regulator		AVR
Sockets (1 phase/3 phase/cable K)		- / - / K
HYDRAULIC POWER REQUIREMENTS		
Flow min.	l/min (gpm)	112 (29.6)
Flow max.	l/min (gpm)	128 (33.7)
Pressure at nominal power output	bar (psi)	280 (4100)
Pressure max.	bar (psi)	420 (6100)
Pressure when unloaded	bar (psi)	40 (580)
HYDRAULIC FLUID REQUIREMENTS		
Viscosity	cSt	10-200 / optimum 25-35
Temperature	°C (°F)	max. 70 (158)***
Filter ratio	µm	25 or better
Cleanliness level	ISO 4406	19/17/14
Cooling capacity requirements	kW	9,1

Gallons are U.S. liquid gallons

* Models are also available by request for all other 60 Hz voltage systems such as, but not limited to, 120/240, 120/208/240, 240/415/480, 277/480V, 347/600.

** Nominal current 1~phase / 3~phase /phase must not exceed maximum load.

*** Depending on the hydraulic fluid.

Other options available by request.



Menotie 3
FI-33470 Ylöjärvi, Finland
tel: +358 3 3488 200
info@dynaset.com



ELECTRICITY

HG Hydraulic Generator
HGV POWER BOX Variable Hydraulic Generator System
HGV Variable Hydraulic Generator System
HWG Hydraulic Welding Generator
HGG Hydraulic Ground Power Generator



HIGH PRESSURE WATER

HPW Hydraulic High Pressure Water Pump
HPW Hydraulic Power Washer
KPL High Pressure Street Washing Unit
HPW-DUST High Pressure Dust Suppression System
PPL High Pressure Pipe Cleaning Unit
HPW-FIRE High Pressure Firefighting System
FP Fire Fighting Piercing Kit
HDF Hydraulic Drilling Fluid Pump
JPL High Pressure Bin Washing System
HSP Hydraulic Submersible Pump



COMPRESSED AIR

HK Hydraulic Piston Compressor
HKL Hydraulic Rotary Vane Compressor
HKR Hydraulic Screw Compressor



MAGNET POWER

HMG PRO Hydraulic Magnet Generator
MAG Lift Magnet
HMAG PRO Hydraulic Magnet



VIBRATION

HVB Hydraulic Vibra
HVD Hydraulic Directional Vibra
HRC Hydraulic Reversal Cylinder



POWER BOOSTING

HPI Hydraulic Pressure Intensifier
HPI-C Hydraulic Pressure Intensifier for Cylinder



KNOW-HOW

Hydraulic Power Take-off (PTO)
Hydraulic Power Unit Technology
De-Icing Technology
Installation Valves
HHK Hydraulic Grinder
HV/HVY Hydraulic Winch / Winch Unit

www.dynaset.com

