

Hidrocilindri HFR2S

M250

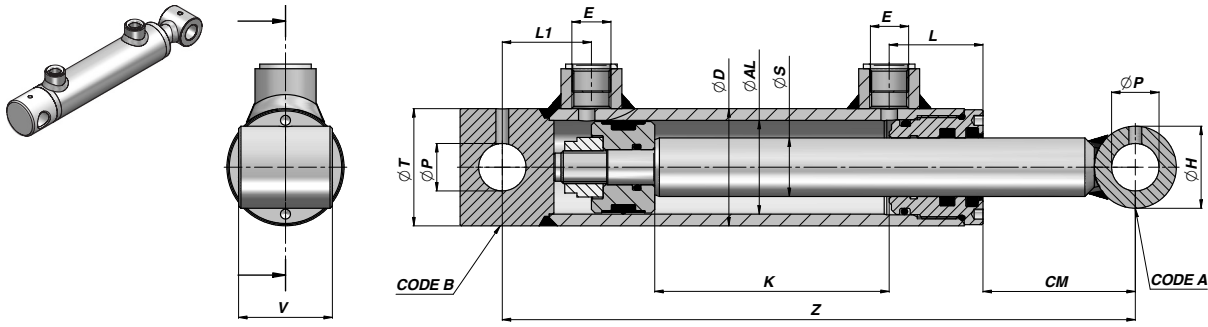

Codice Code Bestell-Nr.	K	Z	kg	E BSP	L	L1	CM	ØP	ØH	V	ØT	Code A	Code B	Codice Code Bestell-Nr.	K	Z	kg
ØD 35 ØAL 25 ØS 16																	
HFR0160050	50	160	1,00														
HFR0160100	100	210	1,20														
HFR0160150	150	260	1,40														
HFR0160200	200	310	1,70	1/4"	33	22	31	12,1	25	25	35	CBF0012025025	CFHR035025				
ØD 42 ØAL 32 ØS 20																	
HFR0200050	50	205	1,70														
HFR0200100	100	255	2,10														
HFR0200150	150	305	2,40														
HFR0200200	200	355	2,80	1/4"	33	35	51	16,2	30	35	40	CBF0016030035	CFHR040032				
HFR0200250	250	405	3,10														
HFR0200300	300	455	3,50														
HFR0200400	400	555	4,20														
HFR0200500	500	655	4,80														
ØD 50 ØAL 40 ØS 25																	
HFR2S0400250100	100	270	3,00														
HFR2S0400250150	150	320	3,40														
HFR2S0400250200	200	370	3,90														
HFR2S0400250250	250	420	4,40														
HFR2S0400250300	300	470	4,80	3/8"	40	38	65	20,25	35	40	50	CBF1020035040	CFHR04002040				
HFR2S0400250400	400	570	5,80														
HFR2S0400250500	500	670	6,70														
HFR2S0400250600	600	770	7,60														
HFR2S0400250700	700	870	8,60														
HFR2S0400250800	800	970	9,50														
ØD 60 ØAL 50 ØS 30																	
HFR2S0500300100	100	300	4,40														
HFR2S0500300150	150	350	5,00														
HFR2S0500300200	200	400	5,60														
HFR2S0500300250	250	450	6,20														
HFR2S0500300300	300	500	6,90														
HFR2S0500300400	400	600	8,10	3/8"	43	42	85	25,25	40	45	60	CBF1025040045	CFHR050025049				
HFR2S0500300500	500	700	9,30														
HFR2S0500300600	600	800	10,50														
HFR2S0500300700	700	900	11,80														
HFR2S0500300800	800	1000	13,00														
HFR2S0500300900	900	1100	14,20														
HFR2S0500301000	1000	1200	15,50														

M250

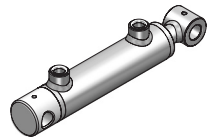
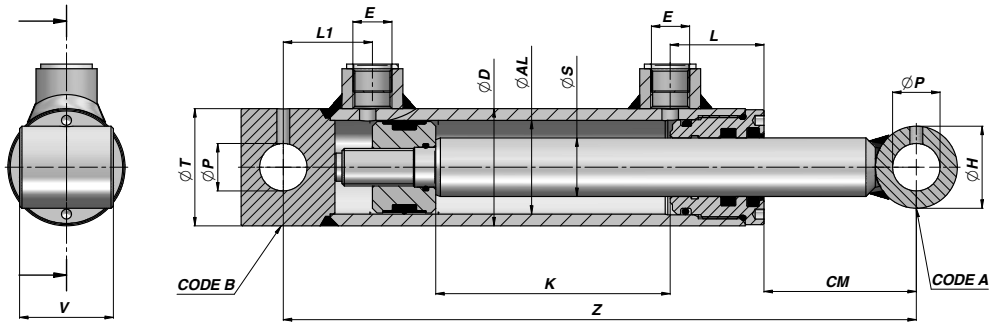

Codice Code Bestell-Nr.	K	Z	kg	E BSP	L	L1	CM	ØP	ØH	V	ØT	Code A	Code B	Codice Code Bestell-Nr.	K	Z	kg	
ØD 70 ØAL 60 ØS 30														ØD 70 ØAL 60 ØS 35				
HFR2S0600300100	100	300	5,60															
HFR2S0600300150	150	350	6,30															
HFR2S0600300200	200	400	7,00											HFR2S0600350200	200	400	7,50	
HFR2S0600300250	250	450	7,70											HFR2S0600350300	300	500	9,00	
HFR2S0600300300	300	500	8,30											HFR2S0600350400	400	600	10,60	
HFR2S0600300350	350	550	9,00											HFR2S0600350500	500	700	12,10	
HFR2S0600300400	400	600	9,70	3/8"	50	36	83	25,25	40	45	70	CBF1025040045	CFHR060025047	HFR2S0600350600	600	800	13,70	
HFR2S0600300450	450	650	10,40											HFR2S0600350700	700	900	15,20	
HFR2S0600300500	500	700	11,00											HFR2S0600350800	800	1000	16,80	
HFR2S0600300600	600	800	12,40											HFR2S0600350900	900	1100	18,30	
HFR2S0600300700	700	900	13,70											HFR2S0600351000	1000	1200	19,90	
ØD 80 ØAL 70 ØS 40																		
HFR2S0700400200	200	410	10,10															
HFR2S0700400250	250	460	11,00															
HFR2S0700400300	300	510	12,00															
HFR2S0700400350	350	560	13,00															
HFR2S0700400400	400	610	13,90															
HFR2S0700400450	450	660	14,90	3/8"	50	46	82	30,25	50	55	80	CBF1030050055	CFHR070030063					
HFR2S0700400500	500	710	15,80															
HFR2S0700400600	600	810	17,70															
HFR2S0700400700	700	910	19,60															
HFR2S0700400800	800	1010	21,50															
HFR2S0700400900	900	1110	23,40															
ØD 92 ØAL 80 ØS 40																		
HFR2S0800400200	200	410	13,00															
HFR2S0800400250	250	460	14,20															
HFR2S0800400300	300	510	15,30															
HFR2S0800400350	350	560	16,40															
HFR2S0800400400	400	610	17,50															
HFR2S0800400500	500	710	19,80	3/8"	60	42	70	30,25	50	55	90	CBF1030050055	CFHR080030060					
HFR2S0800400600	600	810	22,00															
HFR2S0800400700	700	910	24,30															
HFR2S0800400800	800	1010	26,50															
HFR2S0800400900	900	1110	28,80															
HFR2S0800401000	1000	1210	31,00															
ØD 115 ØAL 100 ØS 50																		
HFR2S1000500200	200	425	21,50															
HFR2S1000500300	300	525	25,00															
HFR2S1000500400	400	625	28,50															
HFR2S1000500500	500	725	32,00	1/2"	66	45	75	30,25	60	70	115	CBF1030060070	CFHR100030063					
HFR2S1000500700	700	925	39,10															
HFR2S1000500900	900	1125	46,10															
HFR2S1000501000	1000	1225	49,60															

MATERIALE - MATERIAL:

TUBO - TUBE - ROHR: ACCIAIO - STEEL - STAHL St 52.3 DIN 2393 ISO H9

STELO - ROD - KOLBENSTANGE:

ACCIAIO - STEEL - STAHL UNI C45 SAE 1045 - CROMO - CHROME - CHROM: 25 MICRON ±5 Rating 9/120 h ISO 10289 - 1999/ISO 9227-NSS

REPARK

WWW.REPARK.LV