

SHT



Ton. 0,7 - 2,1



Ton. 5 - 12

SCRAP
ROTTAME
RUBBLE
MACERIE
WASTE MATERIAL
RIFIUTI

SpiderKing



No need to remove cylinders to change hoses
Tubi sostituibili senza smontare i cilindri.

Fittings of the hoses are at the back of cylinders and therefore protected
I raccordi dei tubi flessibili sono protetti dietro ai cilindri.

The first and only orange peel grapple available with conic pins for loader cranes!

La prima e unica benna a polipo per autocarri ad avere i perni conici!

Powder coating
Verniciatura a polveri

Innovative design with rounded shape to avoid build-up of material

Design innovativo con forme arrotondate per permettere al materiale di scivolare via.

All conic pins to eliminate play (unique in the industry)

Tutti i perni sono conici con recupero del gioco. (unico nella categoria)

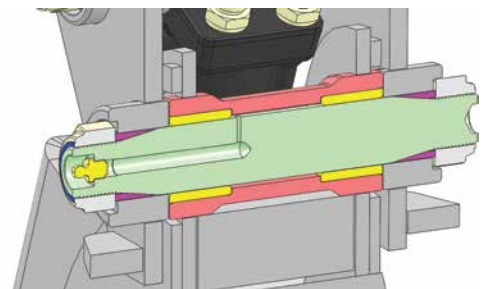

This system allows an easy elimination of play between pin and bushing caused by wear by tightening the nuts of the pin.

Grazie a questo sistema i giochi causati dall'usura tra perno e boccia vengono compensati semplicemente serrando i dadi del perno.

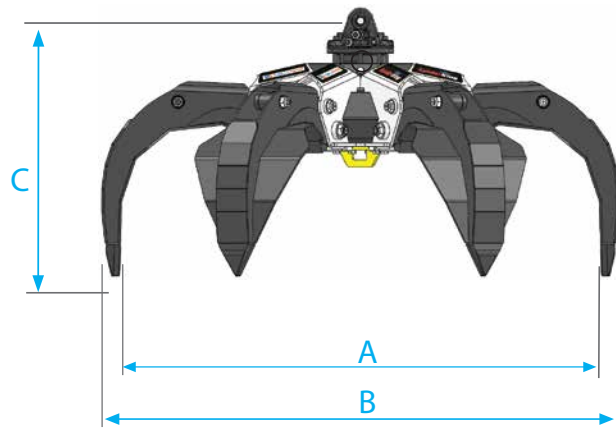
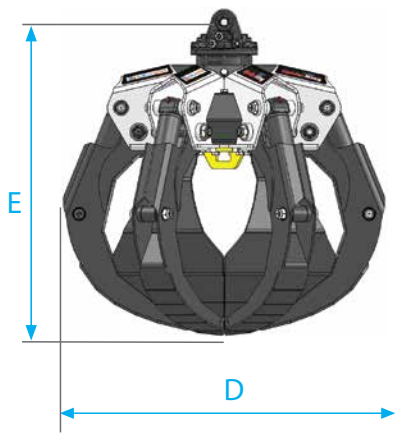

Type of link
Attacchi disponibili



Model Modello	Link type Tipo attacco	Capacity Capacità		Load Portata	Pressure Pressione	Teeth Pale			Dimensions Dimensioni				
		Lt.	Kg.						Ton.	Max Bar	N.	Ton.	Ton.
SHT 255	PE	250	378	2,5	320	5			1440	1560	576	1060	680
SHT 255	K (GV 6)	250	424	2,5	320	5	0,7-1,5	5-7	1440	1560	877	1060	980
SHT 255	K1 (GV 12 S)	250	435	2,5	320	5	0,7-1,5	5-7	1440	1560	910	1060	1013
SHT 256	PE	250	420	2,5	320	6	0,8-1,6	6-8	1440	1560	570	1060	680
SHT 256	K (GV 6)	250	466	2,5	320	6	0,8-1,6	6-8	1440	1560	870	1060	980
SHT 256	K1 (GV 12 S)	250	477	2,5	320	6	0,8-1,6	6-8	1440	1560	910	1060	1013
SHT 305	PE	300	410	3	320	5	1-2	7-11	1655	1800	615	1190	800
SHT 305	K (GV 6)	300	456	3	320	5	1-2	7-11	1655	1800	915	1190	1100
SHT 305	K1 (GV 12 S)	300	467	3	320	5	1-2	7-11	1655	1800	948	1190	1133
SHT 306	PE	300	446	3	320	6	1-2,1	8-12	1655	1800	615	1190	800
SHT 306	K (GV 6)	300	492	3	320	6	1-2,1	8-12	1655	1800	915	1190	1100
SHT 306	K1 (GV 12 S)	300	503	3	320	6	1-2,1	8-12	1655	1800	948	1190	1133



Crane capacity refers to crane boom at its maximal extension. This data are indicative.
To choose the correct attachment check also crane lift capacities.
La portata della gru si intende con il braccio tutto sfilato. Questo dato è puramente indicativo,
per abbinare la giusta attrezzatura, è necessario consultare il diagramma delle portate della gru.



This data are indicative. To choose the correct attachment check also excavator lifting capacities.
Il peso dell'escavatore è indicativo, per abbinare la giusta attrezzatura, è necessario consultare il diagramma delle portate dell'escavatore.

OPTIONS ACCESSORI



Check valve
Valvola di blocco semplice effetto



Crane link (AG 60 - AG 100)
Staffa basculante per gru (AG 60 - AG 100)



Excavator link (AG 60 - AG 100)
Staffa basculante per escavatore (AG 60 - AG 100)



Suspension plate female (AB 060)
Attacco femmina (AB 060)



Mechanical rotator (AD 060)
Rotatore meccanico (AD 060)



Bolted lower hook
Gancio inferiore smontabile

