

STARK[®] STRONG, STRONGER, STARK

**PRO
SERIES**

STARK -BUCKET SPREADER

- Efficient and versatile sand spreader for professional use
- Robust structure with high quality components ensure durability of the product
- Large volumes, the widest discharge width/total width of the bucket on the market
- Easy to do maintenance and lubrication enables efficient sand spreading operation



- The wide range of STARK -spreader buckets are designed for 2 to 25 tons of chassis.
 - The STARK sand spreader buckets fit for front hitch/front loader and rear hitch.
 - Due to the sealed structure of the spreading axle, salt spreading can be done too.
 - Standard accessories includes double pressure relief valve, flow control valve, crusher shaft, spreader bar shields and a lip plate of 500 HB.
 - The bolted STARK-fit adapter is easy to change to match with any chassis (excluding HK 450T -model).
 - Quick, safe and easy to do bearing greasing, chain lubrication and adjustment without opening the protective cover.
 - The spiral pattern of the spreader shaft and the stepless hydraulic rotation speed control allow accurate sand spreading thus saving sand materials.
 - The robust structure and functionality of the bucket is based on features like stiffener beams, high strength structural steel, smooth inner surface of the bucket, robot-welded design, bucket support, 3-point support rod, hot dip galvanizing option.
 - The higher tilting angle of the adapter surface increases work efficiency.
 - The new design of the discharge opening allows sealed shaft structure, prevents the shaft from jamming and reduces wear on the sealing rubber.
-
- Accessories: lifting cylinder with lock valve (HK560-HK 3010), hot dip galvanizing.

REPARK
www.REPARK.lv

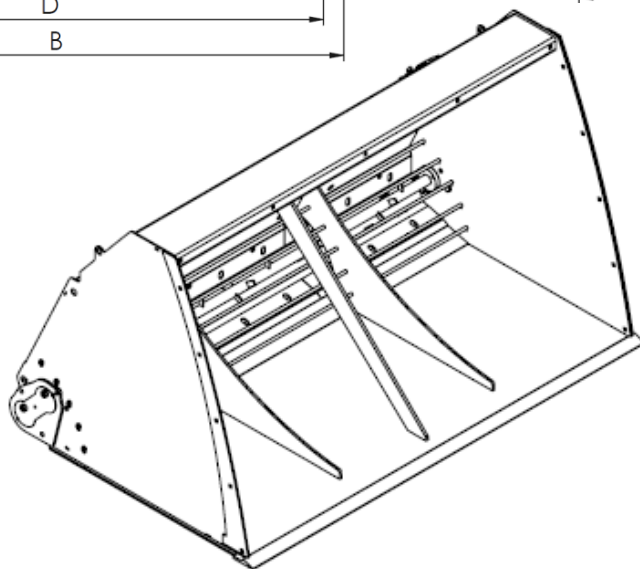
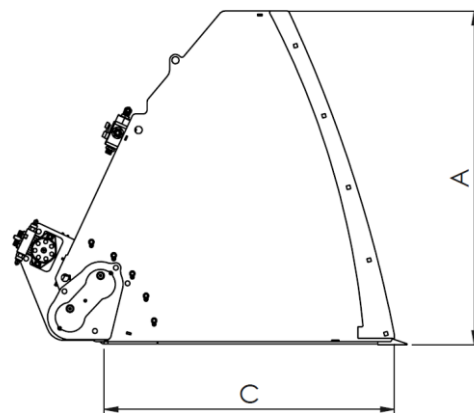
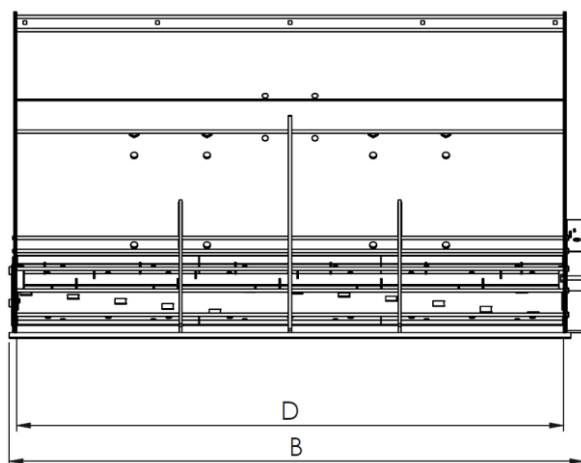

Product	Bucket height (mm)	Bucket width (mm)	Bucket depth (mm)	Graveling width (mm)	Tilting angle of the adapter surface (°)	Bucket water-tightness (m ³)	Bucket capacity (m ³) (SAE 2:1)	Weight (kg) *
	A	B	C	D				
HK 310	738	1300	580	1230	40	0,30	0,36	250
HK 400	740	1490	680	1400	40	0,40	0,44	320
HK 450T	560	1600	727	1400	0	0,45	0,45	340
HK 560	820	1790	750	1700	25	0,56	0,65	415
HK 710	830	1790	750	1700	25	0,71	0,76	435
HK 1010	950	2090	950	2000	25	1,00	1,20	540
HK 1400	1065	2090	950	2000	25	1,40	1,60	577
HK 1800	1175	2090	1220	2000	25	1,80	2,30	700
HK 2200	1300	2090	1220	2000	25	2,20	2,70	755
HK 2600	1400	2490	750	2400	25	2,60	3,20	990
HK 3010	1400	2490	750	2400	25	3,00	3,50	1045

**Weight includes the fittings. Note! Weight may vary depending on fitting type